

LEADWELL
LEADWELL CNC MACHINES MFG., CORP.



In search of excellence

Exceeding Your Expectation, Leading Into A Greater Future

LEADWELL CNC MACHINES MFG., CORP.



No.8, Xingke Road, Houli District, Taichung City 421007, Taiwan
T: 886 - 4 - 25589008
F: 886 - 4 - 25589027
E-mail: sales@leadwell.com.tw

www.leadwell.com.tw

* All performance are based on 220V/3PH/60HZ. Specifications are subject to change without notice.

NV Series

V-40iL/V-50L
V-60S/V-60i/V-80i

High Performance Machining Center

► High Performance

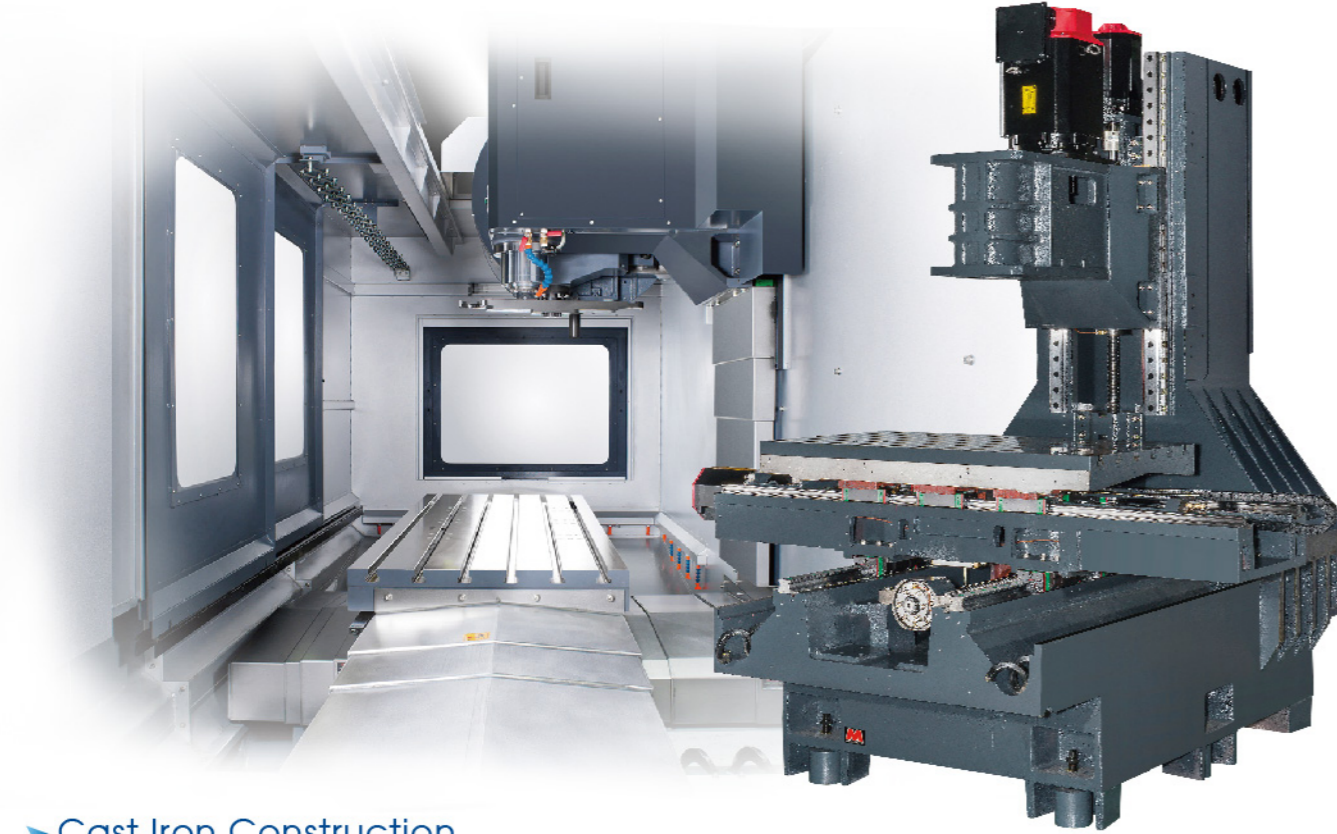

► Cast Iron Construction

LEADWELL use only top quality well-ribbed castings. Finite Element Analysis is used on each new casting to determine the size and location of all internal ribs ensuring high torsional stiffness and minimum vibration. The cast iron base column, saddle, headstock, and tables have over 10 times the dampening capacity of those made from steel resulting in superior cutting performance.

► High Rigidity

- FEA Analysis
- High rigidity structure design
- Dual nuts ball screw design in X and Y axis
- The new wider base and saddle Improved machine rigidity
- Saddle one piece design

► High Reliability

- Roller type motion system
- 3 Axis absolute motor
- One piece telescope design in rear Y axis
- Ball screw bearing lubrication system design
- Front chip disposal system with surrounding coolant system

► High Efficiency

- Rapid feed rate 48/48/48 mm
- Spindle speed 10000/12000,15000 rpm(optional)
- Tool change time T to T 1.8 sec
- Tool change time C to C 4 sec

► High Flexibility

- 30 tools magazine available
- 4/5 axis rotary table available

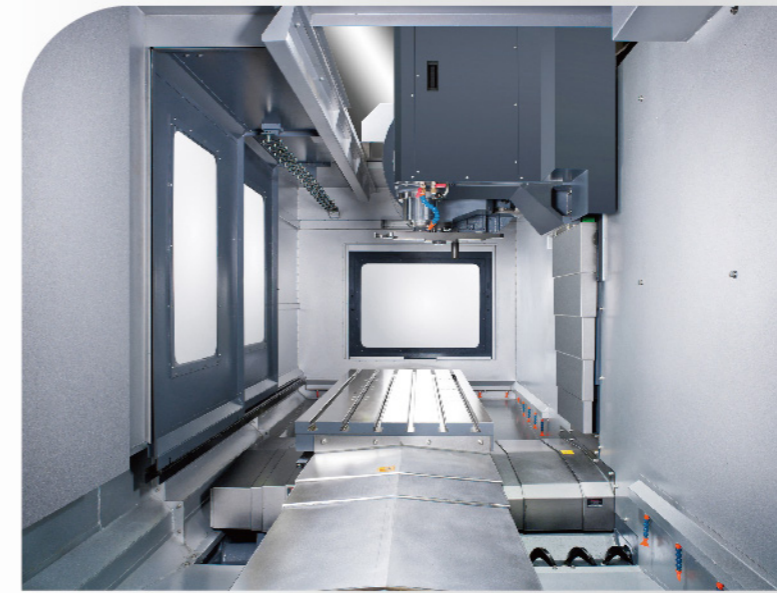

Surrounding coolant system

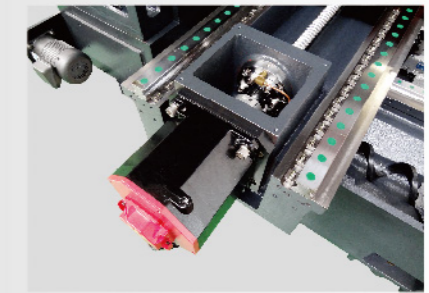

3 Axis absolute motor

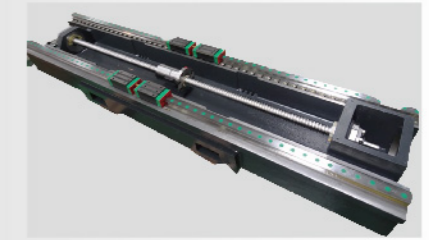

Saddle one piece design

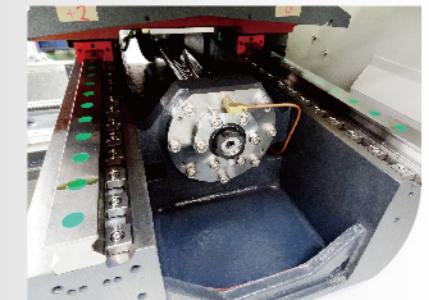
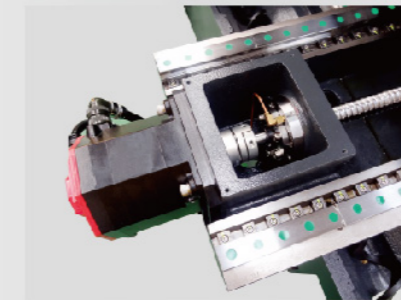
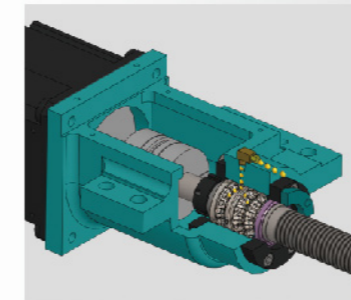

► Three Axis Bearing Oil Lubrication System

- 1 Extend bearing life
- 2 Reduce bearing temperature
- 3 Creates positive pressure within bearing to prevent the entry of foreign matters.

FEA REPORT(Finite Element Analysis)

► Optimum

- Section areas
- Moments of inertia
- Torsional constant
- Plate thickness
- Bending stiffness
- Transverse shear
- Vibration reduce

► With FEA you can:

1. Predict and improve product performance and reliability.
2. Reduce physical prototyping and testing.
3. Evaluate different designs and materials.
4. Optimize designs.

V-50L

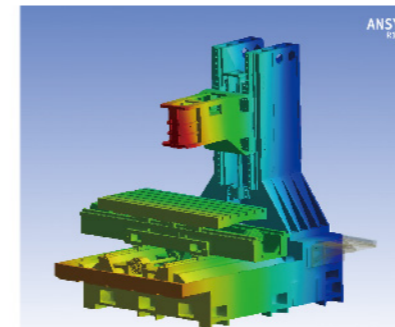

X AXIS

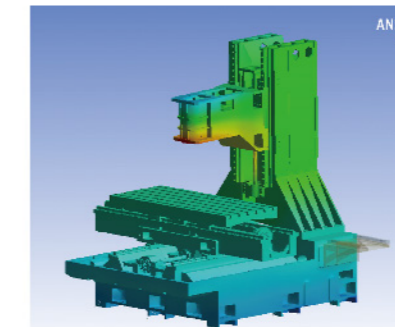

Y AXIS

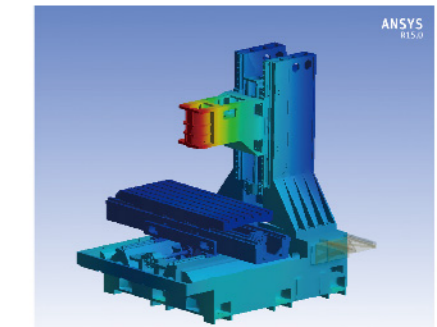

Z AXIS



Auto Tool Change System



Arm Type Magazine
24 tools / 30 tools(opt.)



Coolant System



Tool Unclamping Oil Cup



Portable MPG



3 Axis Pretension



Ergonomic Design 0-90°
swivel control



Alarm Lamp



▶ **Cartridge Type Spindle**

The heavy-duty spindle utilizes FAG, NSK or SKF bearings to allow heavy cutting. Oversized disk springs used to hold the tool in the spindle are tested for long life. The high retention force of the springs reduce tool movement, improve tool life, allow heavier cutting, reduce chatter & create a better part finish. This spindle is prepared to easily add the CTS option.



▶ **Rigid Tapping**

The encode is directly attached to the high-performance spindle motor. The spindle is then synchronized with the Z axis motion. This synchronization eliminates the need for expensive floating tap holders and prevents thread distortion and thread pullout.

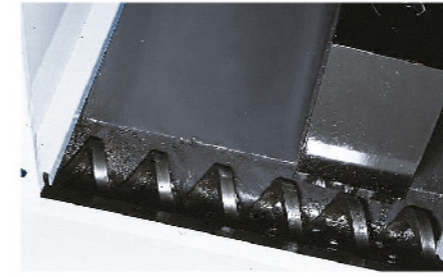

Chip Removal

LEADWELL use chip augers on both sides of the machine and provides high volume coolant to wash the chips from the work area. The augers move the chips into the disposal container, which eliminates the need for an operator to manually remove chips. This system eliminates operation intervention and reduces non-cutting time.

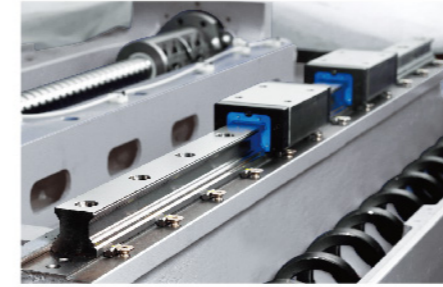

Linear Guide Ways

LEADWELL use linear guideways that feature zero clearance and fully-loaded carrying capacity in all directions. The ways consume less power and require no adjustments. The linear guideways outperform all other types of ways used today. Additionally, each way is automatically lubricated independently to increase life.

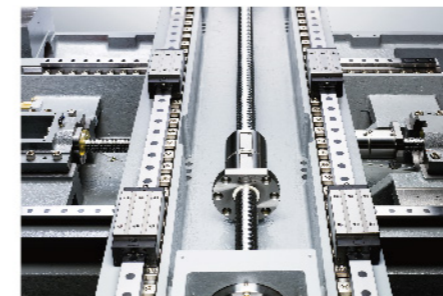

High Speed Roller Bearing Guide Way

It can provide higher rigidity and make the movement more smooth and stability, especially for the request of high accuracy and heavy load.



Directly Coupled Servo Motors

The servo motors are connected to the ball screws with rigid shaft couplings. These couplings ensure that even under severe loading from sharp corner machining, precise interpolation is achieved. This design is superior to both and flexible shaft coupling designs.



Double Nut Designed Ball Screws(with X/Z axis)

LEADWELL use only premium quality preloaded double-nut ball screws from the high-quality supplier. And each ball screw is accurately aligned parallel to the guideways and anchored at both ends. They are then pre-tensioned to improve machine stiffness. The rotational torque variations inspected to guarantee a non-binding, highly accurate, and long-running component with this design, it can exceed customer requirements for accuracy and maximum life.

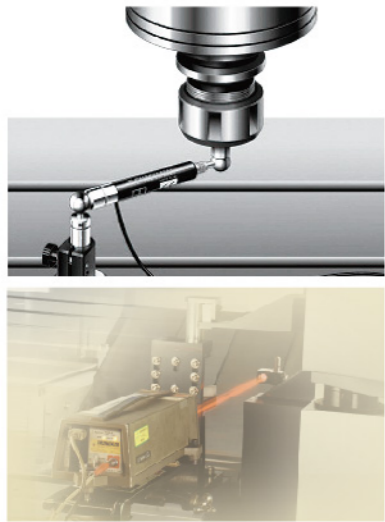

► **Ball Bar Testing**

LEADWELL use a stringent ball bar test that checks not only linear accuracy but also machine geometry. This test ensures that each machine meets the three-dimensional squareness and accuracy requirements.

► **Laser Calibration**

Lasers are used to measure the positioning accuracy of every machine over the full travel of each axis. LEADWELL uses these measurements to compensate each axis so that each machine meets the high accuracy requirement. Each machine is shipped with an accuracy chart.

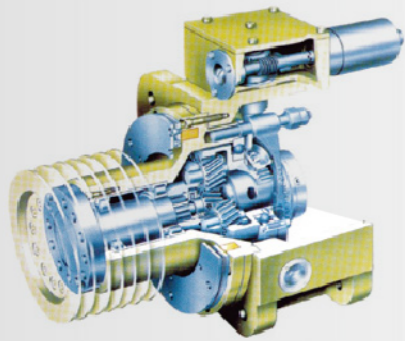

► **High Torque Spindle Option**

The cutting torque is maximized by combining the German ZF two speed gearbox with the oil cooled main spindle. The gearbox has its own separate lubrication system.

► **Features :**

- Over 95% efficiency
- Quiet gears
- Heat is not transmitted to the main spindle
- Gear vibration is not transmitted to the main spindle
- Minimum backlash

► **Spindle Probe Option**

LEADWELL's spindle probe can automate workpiece setup and inspect parts.

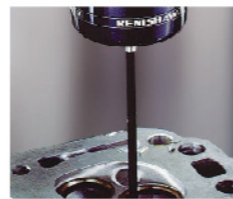

► **Oil Skimmer Option**

Designed for collecting the oil dust in the coolant tank for reclamation and meeting environmental protection requirements.

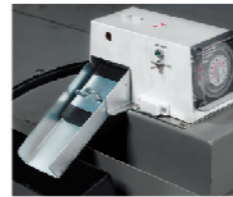

► **Spindle Annular Coolant Jet with 8 Nozzles Option**

This unique spindle annular coolant jet with 8 nozzles option provides a ring around spindle nose where powerful coolant fluid is coming out to cool down/lubricate workpiece and tooling from all sides.



► **4th & 5th Axis Rotary Table Option**

This 4th & 5th axis rotary table option boosts productivity by allowing more machining with a single set-up. It also can turn the machine into a 4 axis contouring machine which adds versatility.

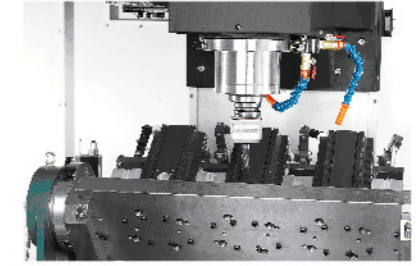

► **Tool Probe Option**

It measures both tool length and tool diameter. It uses macro programming to automatically define and update tool offsets. This option will easy setup and check for broken tools.

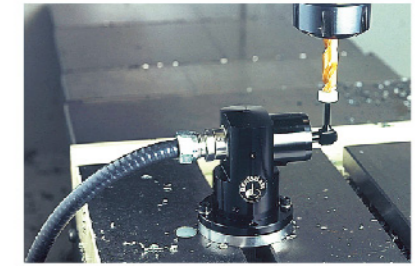

► **Programmable Coolant Nozzle Option**

This unique programmable coolant nozzle option provides precise coolant control. It allows the NC program to change the coolant direction during the machining cycle. This option eliminated operator adjustment causing unnecessary downtime.

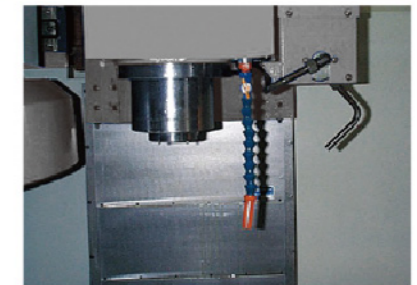

► **Coolant Through Spindle Option**

The optional CTS includes an auxiliary high-pressure pump, which supplies high-pressure coolant to the cutting edge. CTS improves tool life, allows both deep hole drilling and blind pocket milling. It also allows higher speeds, which reduces cycle time.



Direct Drive Spindle
12000/15000 rpm



Spindle Head
Cooling System



Automatic Workpiece
Measurement



20 Bar High
Pressure Pump

More than a machine

Leadwell is never simply about building a machine and to launch onto the market. Our years of experience, we learn that the right programs must be developed to ensure the competitiveness of the users.



Pre-machining setting

It contains the function that the operator will frequent use before the operations. This including the coordinates setting, tool measurement, tool magazine measurement, and the calculator function.



Leadwell Assistor

The assistor contains the functions to help the user to optimize the machine setting.



Machining setting

It includes the parameter data setting, and all the other statistics of the machines; such as the accumulated machining time, and the tool management.



Maintenance

Operators would be able to gain the current status of the machine, and to access the internet to obtain more useful information.

14 difference useful functions



Machined work pieces.

Users' full satisfaction have always been Leadwell's main focus.

PERFORMANCE

V-50L

FACE MILL	
Removal Rate	400cc/min.
Tool	Ø100mm
Spindle Speed	1500rpm
Feed Rate	1000mm/min
Width of Cut	80mm
Depth of Cut	5mm

U-DRILL	
Drilling	Ø60mm
Tool	Ø60mm
Spindle Speed	1500rpm
Feed Rate	100mm/min
Depth of Cut	55mm

Material:S45C

END-MILL	
Removal Rate	280cc/min.
Tool	Ø20mm
Spindle Speed	1850rpm
Feed Rate	700mm/min
Width of Cut	20mm
Depth of Cut	20mm

RIGID TAP	
Tapping	M20
Spindle Speed	1000rpm
Feed Rate	2500mm/min.

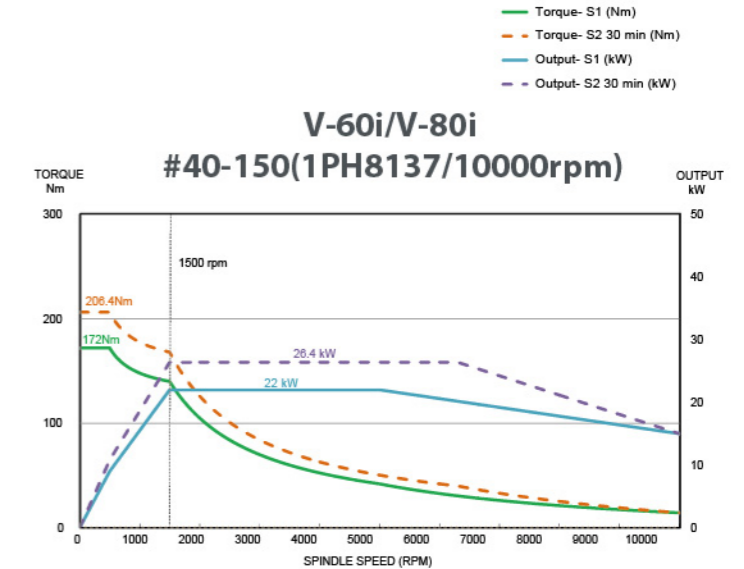
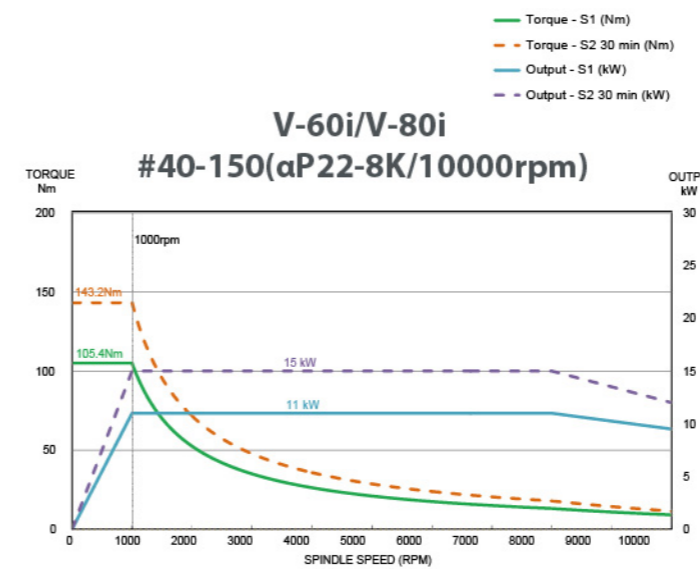
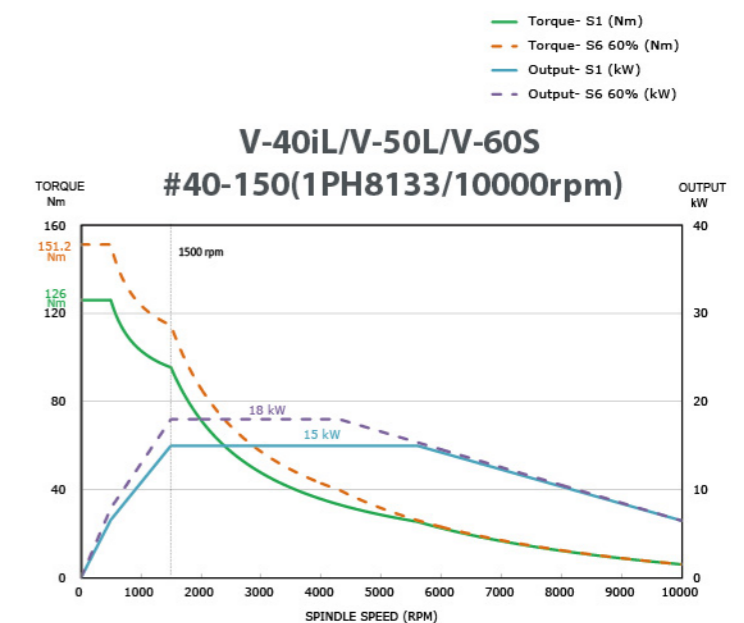
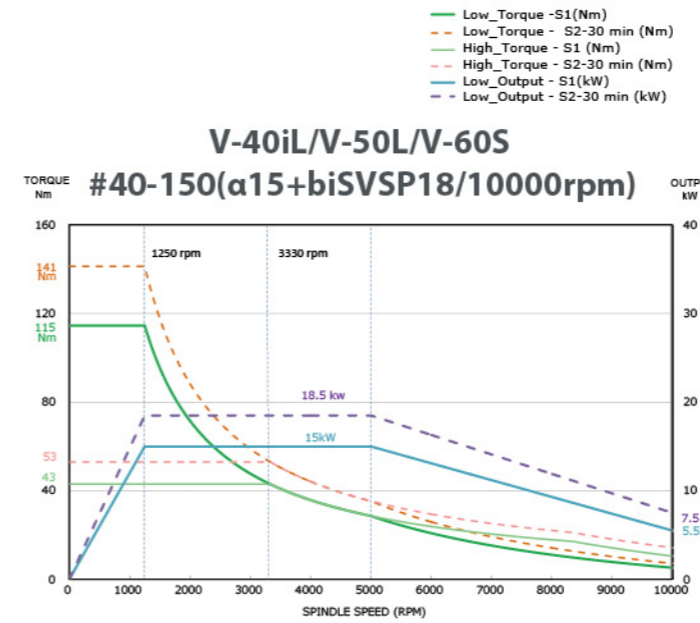

OUTLINE DIMENSION

▶ V-40iL

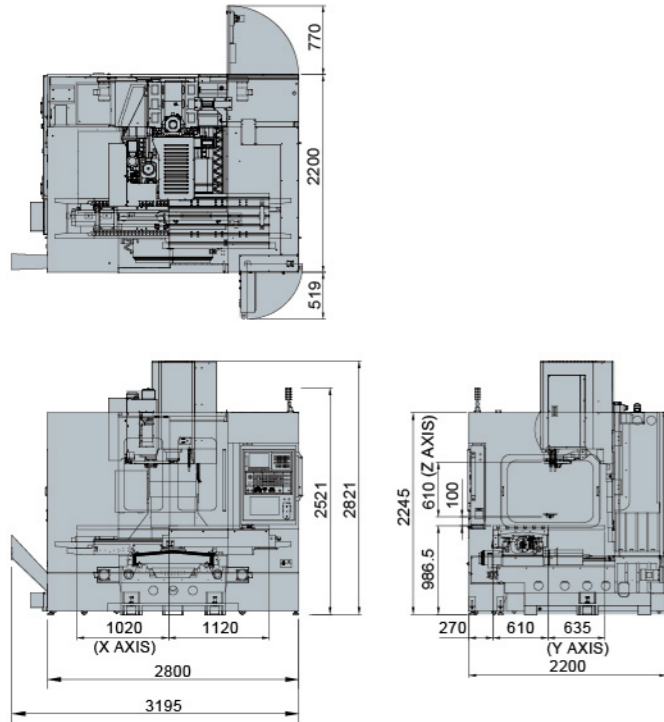

▶ V-50L

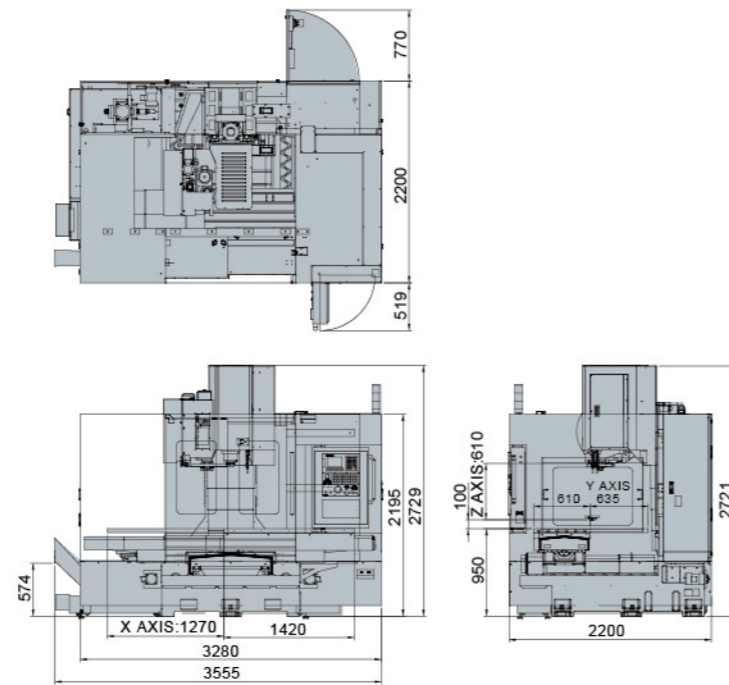

▶ V-60S

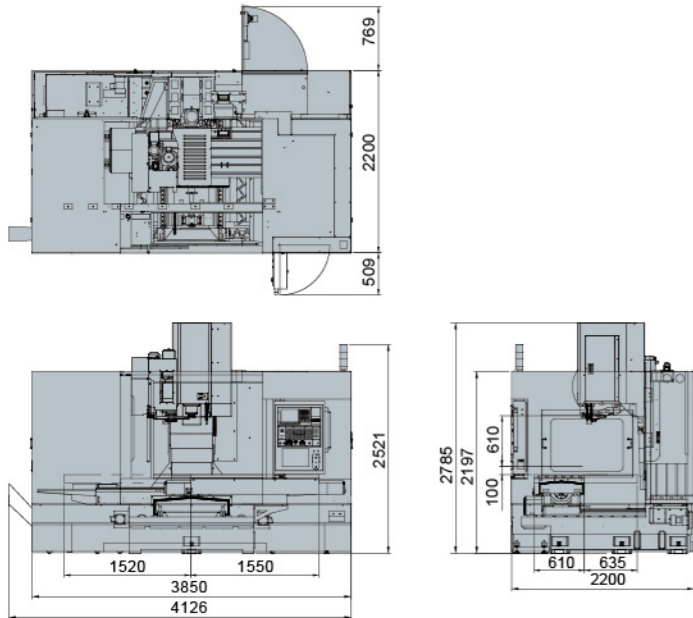

▶ V-60i

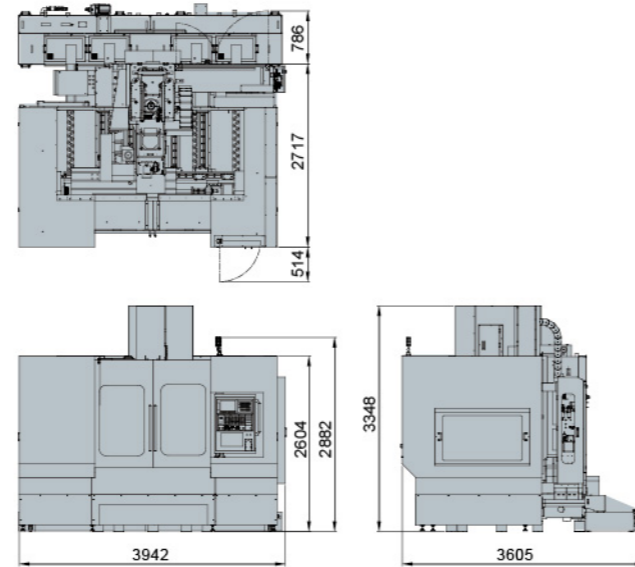

OUTLINE DIMENSION

▶ V-80i

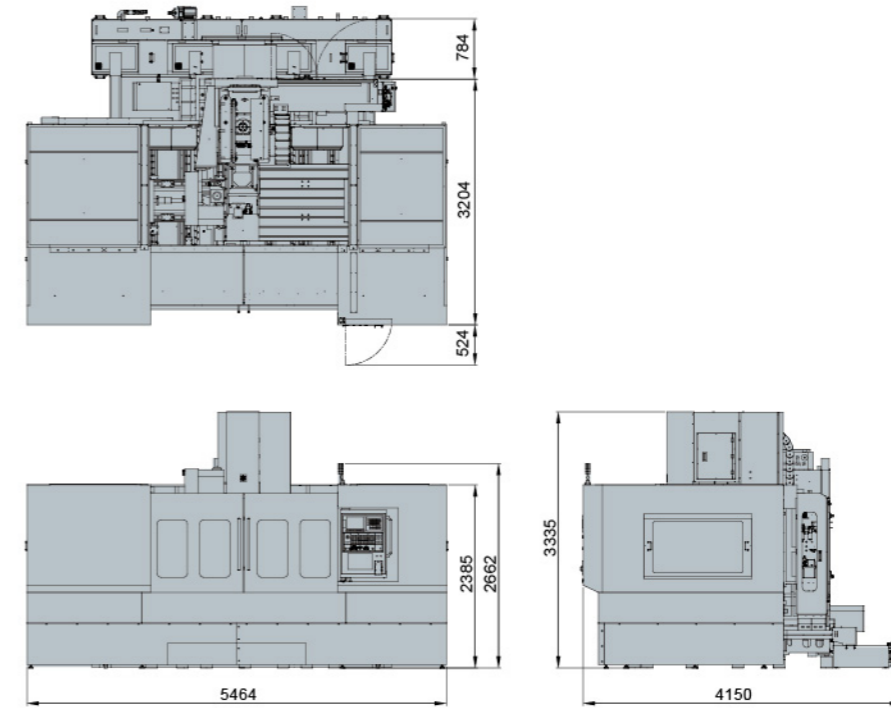

INTERNAL DIMENSION

▶ V-40iL

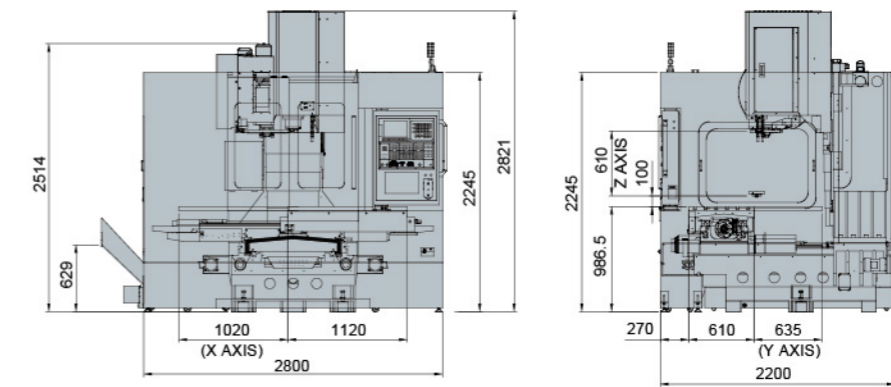

▶ V-50L

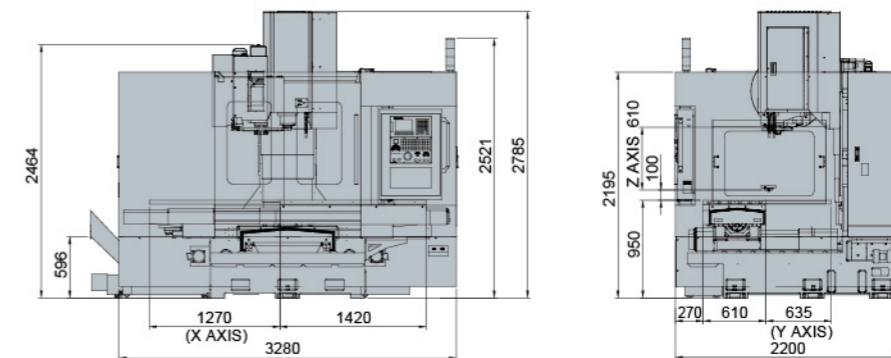

► V-60S

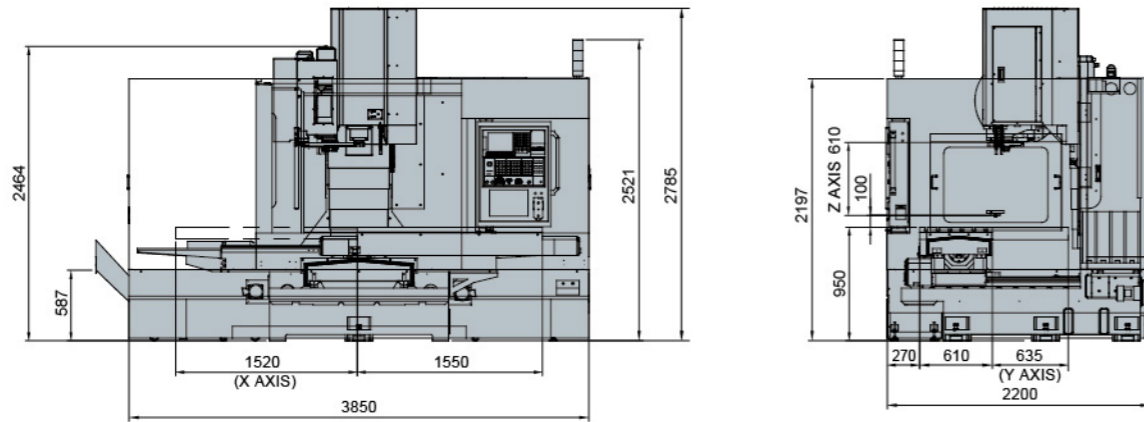

► V-60i

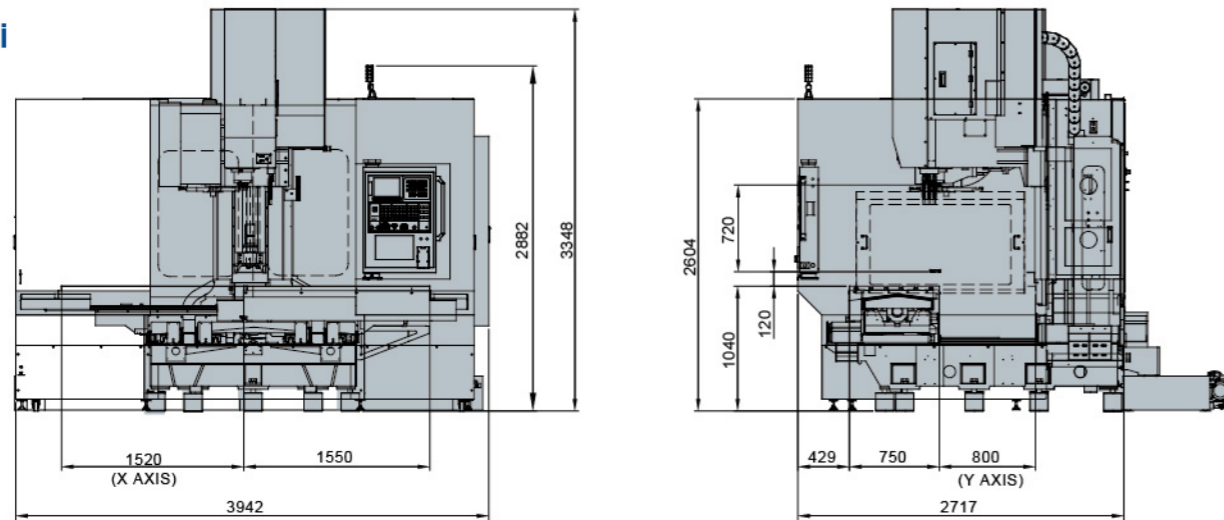

► V-80i

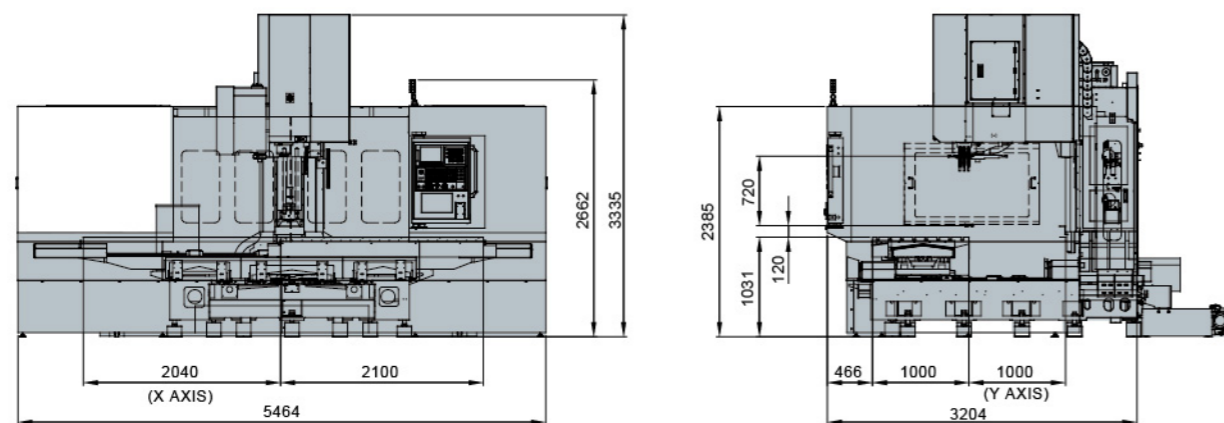

Pull Stud

Standard

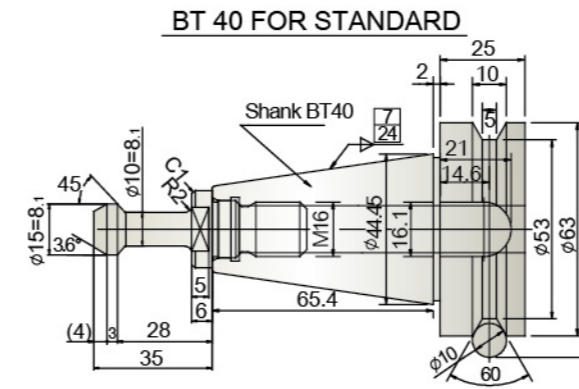

Optional

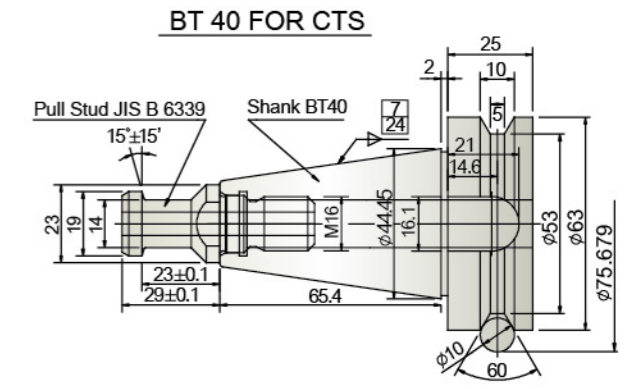

Optional

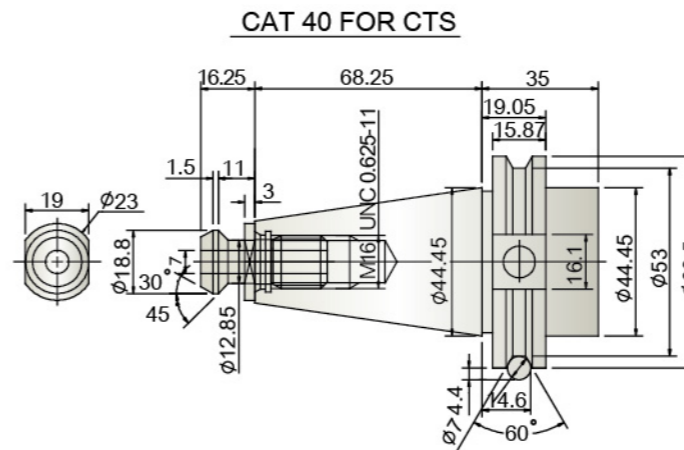

DIN 40 FOR CTS

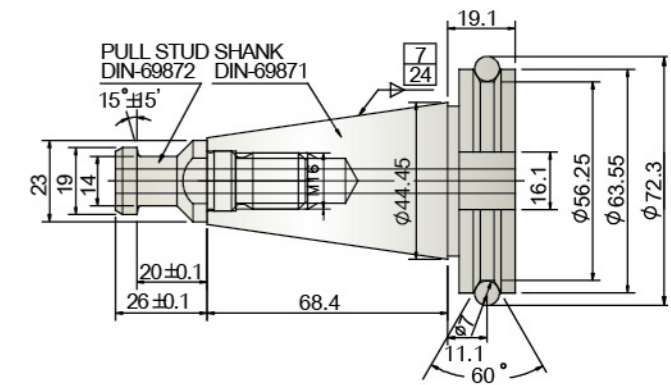

Cartridge Type Spindle



BBT Two face contact

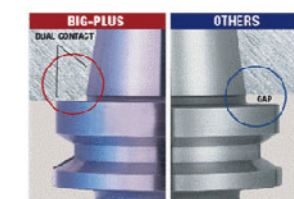

MACHINE SPECIFICATIONS

ITEM	MODEL	V-40iL	V-50L	V-60S	V-60i	V-80i
A.T.C	Type	Arm	Arm	Arm	Arm	Arm
CAPACITY	Unit					
X axis travel	mm (in)	1020(40.2)	1270(50)	1520(59.8)	1520(59.8)	2040(80.3)
Y axis travel	mm (in)	635(25)	635(25)	635(25)	800(31.4)	1000(40)
Z axis travel	mm (in)	610(24)	610(24)	610(24)	720(28.3)	720(28.3)
Distance from table top to spindle end	mm (in)	100-710(4-27.9)	100-710(4-27.9)	100-710(4-27.9)	120-840(4.8-33)	120-840(4.8-33)
Distance from column front to spindle center	mm (in)	635(25)	635(25)	635(25)	829(32.6)	1000(40)
TABLE						
Table size (L x W)	mm (in)	1120X610(44X24)	1420X610(56X24)	1550X610(61X24)	1550X750(61X29.5)	2100X1000(82.7X40)
Max. table load weight	kg	1200(2646)			1500(3300)	1800(3960)
T-slot size	mm	18TX100X6	18TX100X6	18TX100X6	18TX125X6	18TX125X8
SPINDLE						
Spindle speed	rpm	10000				
Spindle nose (normal size, No.)		7/24 TAPER, NO.40	7/24 TAPER, NO.40	7/24 TAPER, NO.40	7/24 TAPER, NO.40	7/24 TAPER, NO.40
Spindle bearing inner diameter	mm(in)	70(2.75)	70(2.75)	70(2.75)	70(2.75)	70(2.75)
FEED RATE						
Rapid traverse X/Y/Z	m/min(ipm)	48/48/36 (1889/1889/1417)	36(1417)	36(1417)	30/30/24 (1181/1181/945)	30/30/24 (1181/1181/945)
Max. cutting feed rate	m/min(ipm)	20(787)			10(394)	10(394)
A.T.C						
Tool storage capacity	pcs	24	24	24	24	24
Max. tool diameter(with adjacent tools)	mm(in)	80(3.15)	80(3.15)	80(3.15)	80(3.15)	80(3.15)
Max. tool length	mm(in)	250(10)	300(11.8)	300(11.8)	250(10)	250(10)
Tool change time T-T (C-C)	sec	1.8/5	1.8/4	1.8/4	1.8/4	1.8/4
MOTORS						
Spindle motor(30 min) FANUC	kw(hp)	18.5(24.8)	18.5(24.8)	18.5(24.8)	15(20)	15(20)
X/Y/Z axis motor	kw(hp)	4/4/4(5.4/5.4/5.4)			4/4/4(5.4/5.4/5.4)	4/4/4(5.4/5.4/5.4)
MACHINE SIZE						
Height of machine (H)	mm(in)	2721(107)	2930(115)	2930(115)	3350(131.9)	3335(131)
Floor space (L x W)	mm(in)	3200X2200 (126X86.6)	3840X2200 (151.2X86.6)	4130X2200 (162.6X86.6)	3945X4020 (155.3X158.3)	5466X4135 (215X163)
Total machine weight	kg	6200	7000	7800	10800	15100
Power requirement	KVA	35	35	35	35	35
Controller	FANUC	Oi-M				

*AVAILABLE CONTROLLER:SIEMENS/MITSUBISHI/FAGOR/HEIDENHAIN

MACHINE ACCESSORIES

ITEM	MODEL	V-40iL	V-50L	V-60S	V-60i	V-80i
Chip conveyor (auger type)		●	●	●	●	●
Work light		●	●	●	●	●
Alarm lamp		●	●	●	●	●
Heat exchanger		●	●	●	●	●
Rigid tapping		●	●	●	●	●
Auto counter for work piece		●	●	●	●	●
Remote MPG		●	●	●	●	●
Surrounding coolant system		■	■	■	■	■
Spindle air purge		●	●	●	●	●
10000rpm spindle		●	●	●	●	●
12000rpm spindle		■	■	■	■	■
15000rpm spindle		■	■	■	■	■
Spindle oil chiller		●	●	●	●	●
Two speed gearbox		■	■	■	■	■
CTS From A		■	■	■	■	■
Linear scale		■	■	■	■	■
Tool overload detection		■	■	■	■	■
Auto tool length measurement (ATLM)		■	■	■	■	■
Automatic workpiece measurement		■	■	■	■	■
Simple tool life management		■	■	■	■	■
Chip conveyor outside machine & chip bucket		■	■	■	■	■
Oil skimmer		■	■	■	■	■
Coolant gun		■	■	■	■	■
Air conditioner		■	■	■	■	■
Rotary table preparation		■	■	■	■	■
Manual tailstock for rotary table		■	■	■	■	■
Through hole drill kit		■	■	■	■	■
DNC link software		■	■	■	■	■
Programmable nozzle		■	■	■	■	■
Programmable air blow		■	■	■	■	■
CTS preparation		■	■	■	■	■
Extra coolant tank		■	■	■	■	■
Spindle annular coolant jet (Arm type ATC)		■	■	■	■	■
Auto door		▲	■	■	▲	▲
ARM 30T ATC		■	■	■	■	■
Table guarding		▲	▲	▲	x	x

● : S.T.D / ■ : O.P.T (DESIGNED) / ▲ : O.P.T (TO BE ADVISED) / X : N/A(NOT AVAILABLE)