

CNC Multi-Turning Center

XXY series



TAKAMAZ

CNC Multi-Turning Center

XY series

From Blank to Finish with a Single Switch!

The answer is here. it's XY series !

From the age of mass production to optimal quantity production
Supporting optimal creation of new things through
intelligent fusion of man and machine,
the XY series is the ideal machine for a new era.

Turning
range

Max. turning diameter
#1 Turret

φ240mm
φ190mm
φ170mm

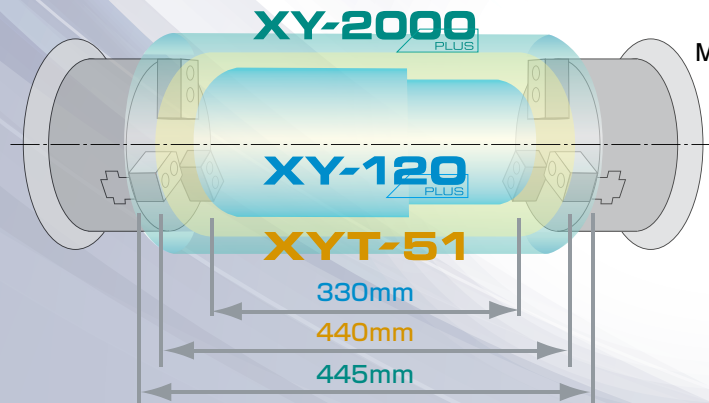

Max. turning diameter
#2 Turret

φ240mm
φ190mm
φ135mm

Max. bar
diameter



※The available turning range varies depending on the chuck size or part shape.

XY-120 PLUS

This middle size multi-turning center is equipped with the sub-spindle X2 axis to enable superimposed cutting and can be installed with an optional sub-turret, which further helps shorten turning time.

Compared to conventional machines, higher-grade motors are used to achieve an OD turning area of 0.87 mm² (10% increase) on the main-spindle side and 0.5 mm² (13% increase) on the sub-spindle side.

※Cutting amount×Feedrate.

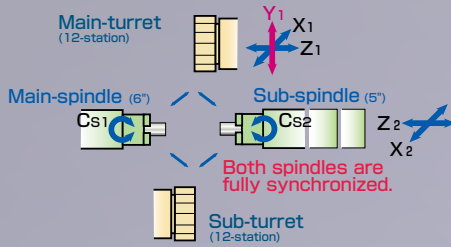

XYT-51 NEW

Suited to bar work up to max. $\phi 51$ mm, and able to accommodate a maximum of 48 turning tools through half indexing or 24 power tools. Increasing motor output beyond that of the existing machines allows it to handle heavy-duty cutting and compound machining.

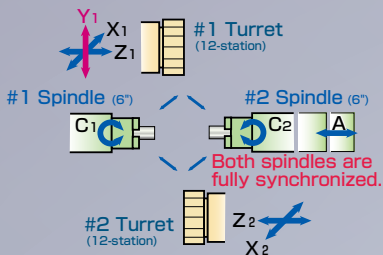

XY-2000 PLUS

Suitable for bar materials of $\phi 65$ mm maximum, 24 power tools can be installed on #1 and #2 turrets, enabling highly efficient multi-turning operation from blank to finish. VDI tooling systems are also available for European countries, which can shorten setup time.

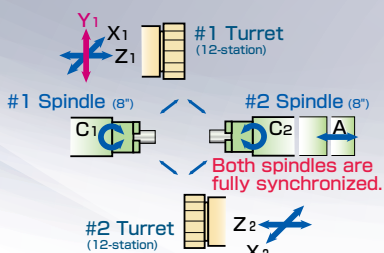

Machines shown in the photos are in standard color. Environmentally friendly powder coating is applied.

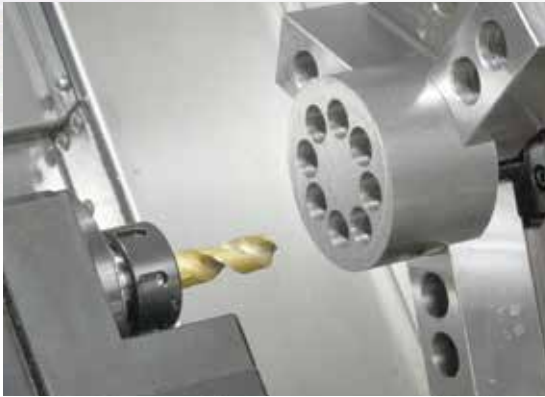

Turning and milling available with the Y axis for power tools

Equipped with a Y axis and milling function, multi-turning operation equivalent to machining centers is possible. By using the Y axis, multi-turning operations such as polar coordinate interpolation and cylindrical interpolation which were conventionally difficult with turning machines are made simpler with high precision.

	Y-axis cutting range	Power tool storage capacity	Power tool capacity
XY-120	± 35mm	12 tools / turret	φ13mm, M8mm
XYT-51	± 35mm	12 tools / #1 turret 12 tools / #2 turret	φ13mm, M12mm φ13mm, M12mm
XY-2000	± 40mm	12 tools / #1 turret 12 tools / #2 turret	φ16mm, M16mm φ16mm, M16mm

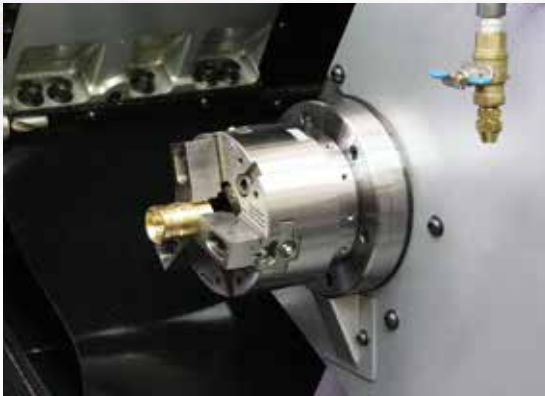

Sub-spindle provided for shaft work and blank-to-finish cutting on both front and back faces

A sub-spindle having the same capability as the main-spindle enables back face cutting of the second process in a single machine structure. Fully synchronized rotation of both spindles offers high precision and uniform finish shaft work.

	Sub-spindle Chuck size	Spindle speed	Stroke
XY-120	5 inches	Max. 5,000min ⁻¹	440mm
XYT-51	6 inches	Max. 5,000min ⁻¹	550mm
XY-2000	8 inches	Max. 4,000min ⁻¹	570mm



Speedy setup change with VDI turrets

Quick change type tool posts (VDI) are featured on both the #1 and #2 turret and greatly reduce the tool mounting time.

	#1 Turret	#2 Turret	Tool storage capacity
XY-2000	No.40	No.40	12 tools / turret

Indexing time (common): 0.2 sec (1 station), 0.6 sec (6 stations)

Power Characteristic Curve

A wide range of high performance motors are available according to your needs from high horsepower to high speed rotation.

XY-120
PLUS

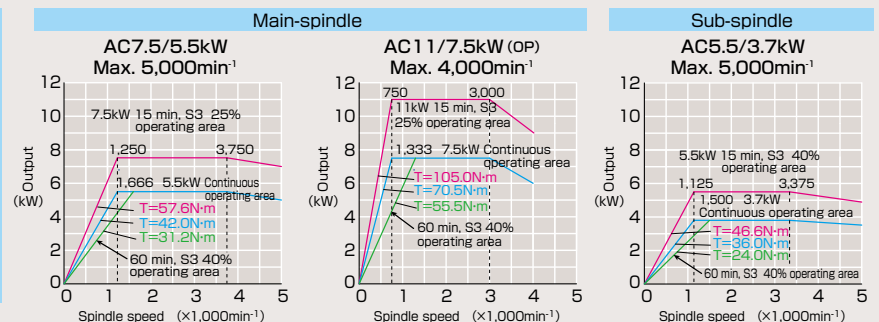



Cylinder blocks
(car air-conditioners)



Pistons



Sleeves, body valves



Gear sleeves

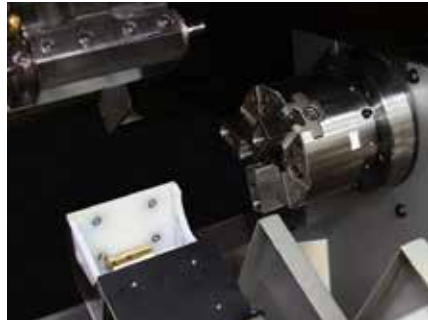

Bar work automated with parts catcher

The parts catcher can be configured to the most appropriate part-receiving timing by programming and, if combined with an automatic bar feeder, enables extended unmanned operation of bar work.



Swivable operation panel for good operability

To reduce the operator's burden, a swivable operation panel is employed in consideration of minimizing the operator's motion area. Operations in good posture support a strain-free, efficient and safe working environment.



FANUC Manual Guide i installed for good and easy-to-use programming

Cutting cycles for milling, turning, inclined cutting and more can be programmed with ease and simulated in realistic graphical representation, which will dramatically shorten programming time.



Chip conveyor for chip accumulation prevention

The slant bed structure of the XY series assures a smooth flow of chips. Even if chips have complex shapes depending on cutting conditions, using a chip conveyor in combination can remove such chips smoothly from the machine.

Consideration to maintenance and environment

For ease of maintenance and good operability, the chuck pressure regulating valve and lubrication pump are arranged on the front face of the machine. A periodical inspection notice function notifies the time of battery replacement and hydraulic pump inspection to support control of maintenance and help keep the machine in top condition all the time. In addition, the XY-120plus is equipped with high-performance motors.

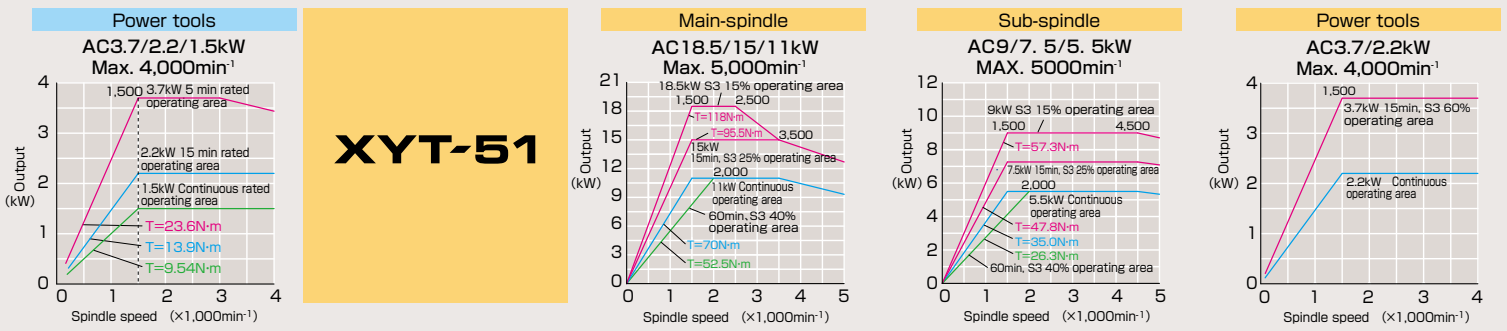

XY-120 PLUS

Superimposed Cutting

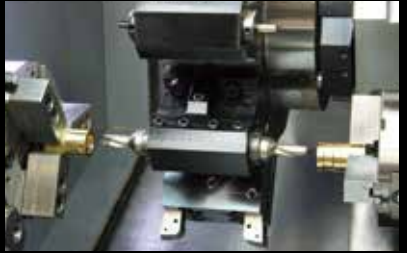

Simultaneous front and back face cutting is available by using the sub-spindle axis.

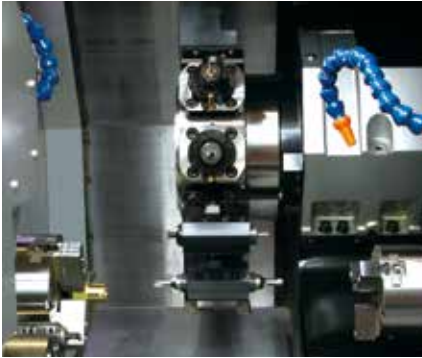

Cycle time shortened with superimposed cutting

X2 axis configuration is added to the sub-spindle slide to enable X- and Z-axis superimposed cutting. An optional sub-turret further enables superimposed cutting simultaneously on the main-spindle and the sub-spindle, which contributes to drastic cycle time reduction. (See the chart below.)

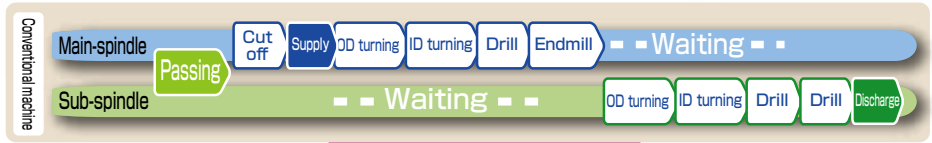

Max. 50% time reduction

*Excluding part supply, passing and discharge time

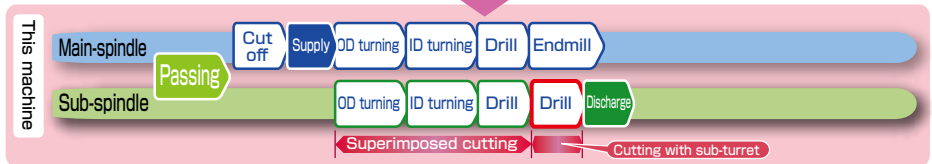

Sufficient tool storage capacity

The 12-station main-turret with the intermediate indexing function has 24 tool storage positions or if a sub-turret is installed 36 tool storage positions, reducing the number of tool setup times that might be required frequently during various kinds various volumes production.

A maximum of 12 power tools for drilling of up to $\phi 13$ mm can be installed.

XYT-51 / XY-2000 PLUS

BALANCE CUT



#1 and #2 turrets are synchronized during OD turning for high precision balance cutting.

By applying two synchronized turning tools (for example, a rough turning tool and a finish turning tool) simultaneously from both sides, part deflection can be dampened, achieving high cutting precision and shorter cycle times.

#1 Spindle side

On the #2 spindle side

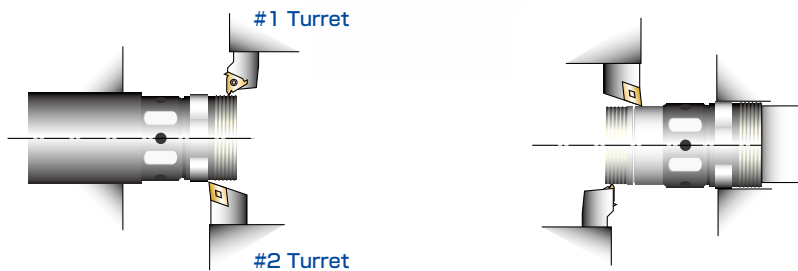

Power Characteristic Curve

A wide range of high performance motors are available according to your needs from high horsepower to high speed rotation.

XY-2000 PLUS

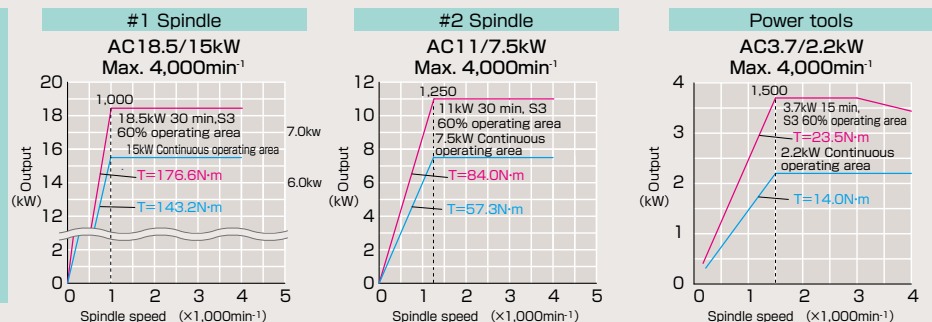

XYT-51 NEW

The XY series machines have a spacious cutting chamber which makes in-machine work such as setup changes easier and provides a turning range flexible with varied workpieces.

Chip expulsion and dust-proofing are also improved compared to existing machines, and the 60° angled cover under the turret reduces retention of chips in the machine, and improves the chip removal capability which is required by a multi-turning center. Linear guides with excellent dust-proofing are adopted.



Sliding door adopted for ease of maintenance

The right side cover of the machine can be slid as a maintenance door. A large maintenance area can be secured, which facilitates maintenance or inspections and helps to reduce machine failures and trouble.

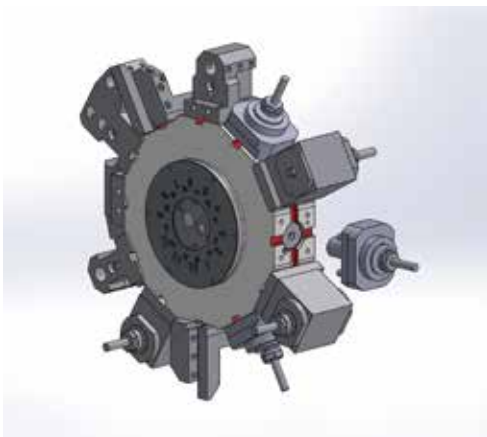

Use of bolt mount system (BMT45)

The XYT-51 adopts the new global standard BMT system. This is a holder securing system using four bolts and key grooves.

It is compatible with a wide range of attachments and a variety of tooling layouts by each holder manufacturer, enabling turning and milling tailored to your needs of production.

Reliable workmanship

The XY series machines employ precision scraped square slideways. With excellent rigidity, these slideways ensure stable cutting accuracy at all times. Based on our proven technology from 60 years of experience in machine tool building, our machines have high durability that withstands long-term use, enhancing customer satisfaction.

XY-2000 PLUS

(Reference values)

OD turning capacity

Cutting cross-sectional area

#1 Spindle side **2.35mm²**
 #2 Spindle side **0.95mm²**

Material	S45C
Spindle speed	500~2,000 min ⁻¹
Cutting speed	150 m/min
Feed rate	0.2~0.4 mm/rev.
Depth of cut	3.0~5.0 mm

Power tool capacity

Drill #1 / #2 Spindle

φ25mm

Material	S45C
Spindle speed	255 min ⁻¹
Cutting speed	20 m/min
Feed rate	0.1~0.25 mm/rev.
Depth of cut	25.0 mm

Surface roughness

#1 Spindle side **0.49μm**
 #2 Spindle side **0.29μm**

Grooving capacity

#1 Spindle side **6mm (L:114mm)**
 #2 Spindle side **5mm (L:87mm)**

Material	S45C
Spindle speed	430 min ⁻¹
Cutting speed	100 m/min
Feed rate	0.1 mm/rev.
Depth of cut	3.0 mm

Out of roundness

#1 Spindle side **0.62μm**
 #2 Spindle side **0.45μm**

Material	C3604BD
Spindle speed	2,000 min ⁻¹
Cutting speed	180 m/min
Feed rate	0.2~0.002 mm/rev.
Depth of cut	0.1 mm

Variation with time (#2 Spindle side)

(change in 8 hours)

15μm

Material	S45C
Spindle speed	Rough 1,600 Finish 2,000 min ⁻¹
Cutting speed	Rough 180 Finish 200 m/min
Feed rate	Rough 0.2 Finish 0.08 mm/rev.
Depth of cut	Rough 2.0 Finish 0.1 mm

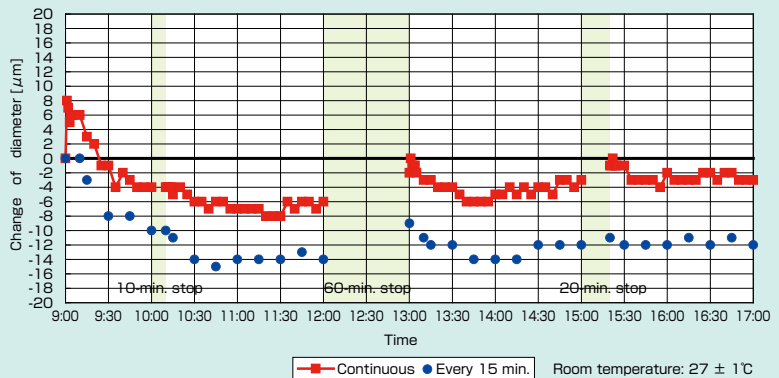

Tooling System

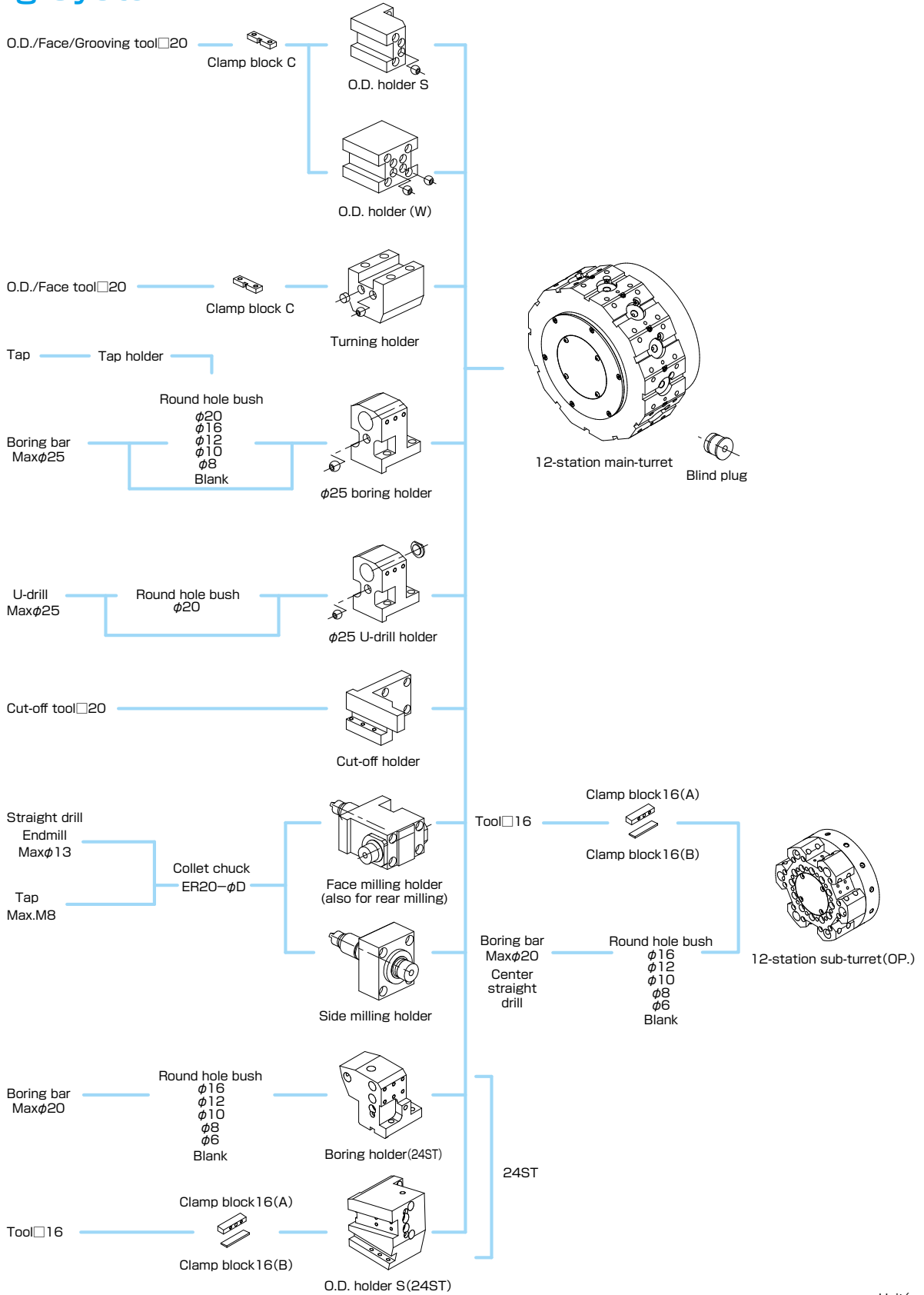

Unit(mm)

Turret interference

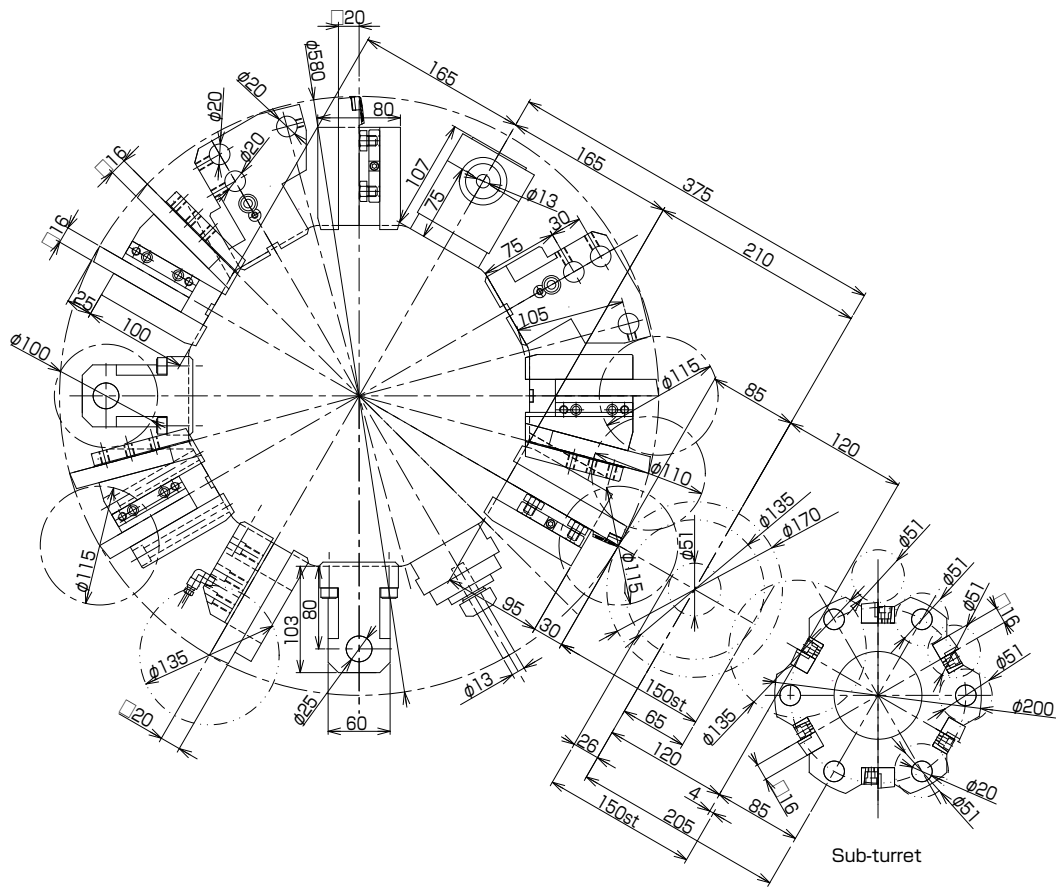

Stroke-Related Drawing

Turning holder

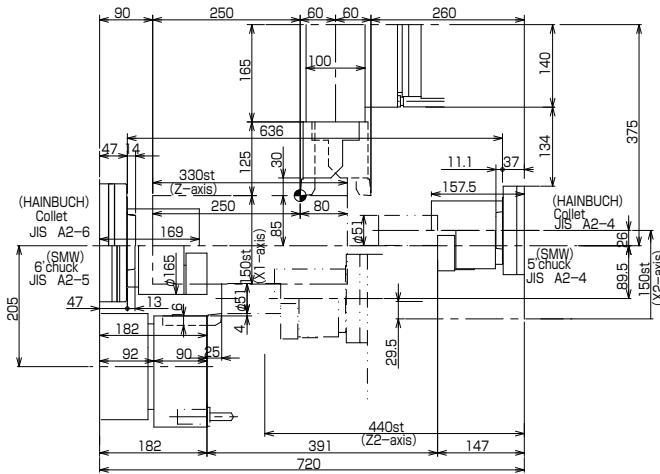

Boring holder

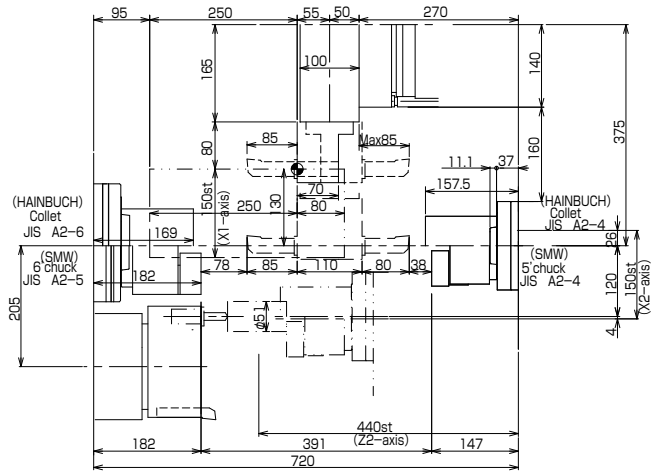

Z-Axis (Face) milling holder

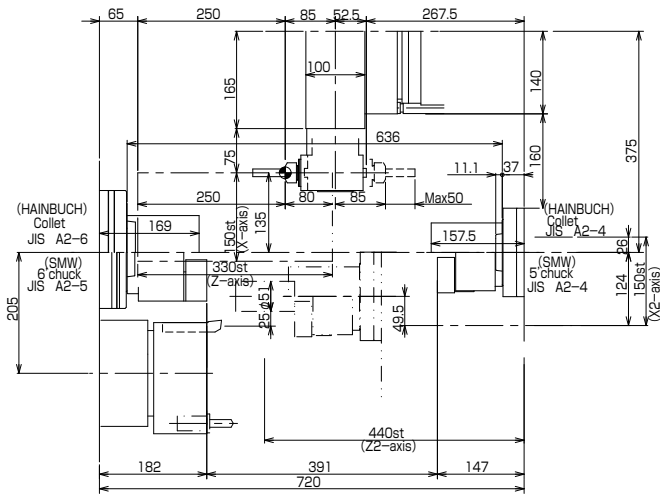

X-Axis (Side) milling holder

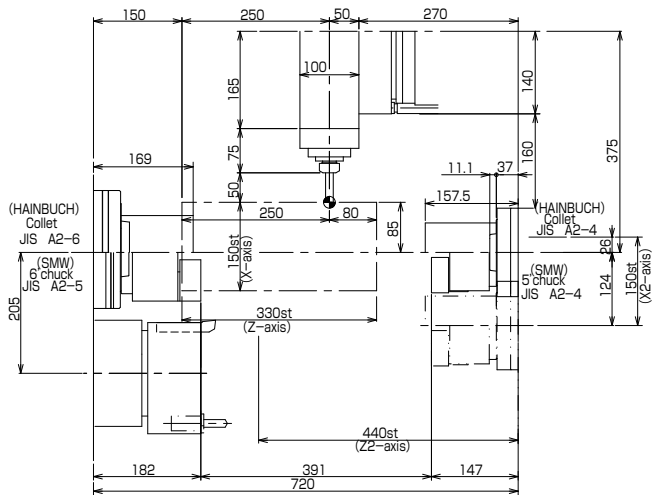

Unit(mm)

Tooling System

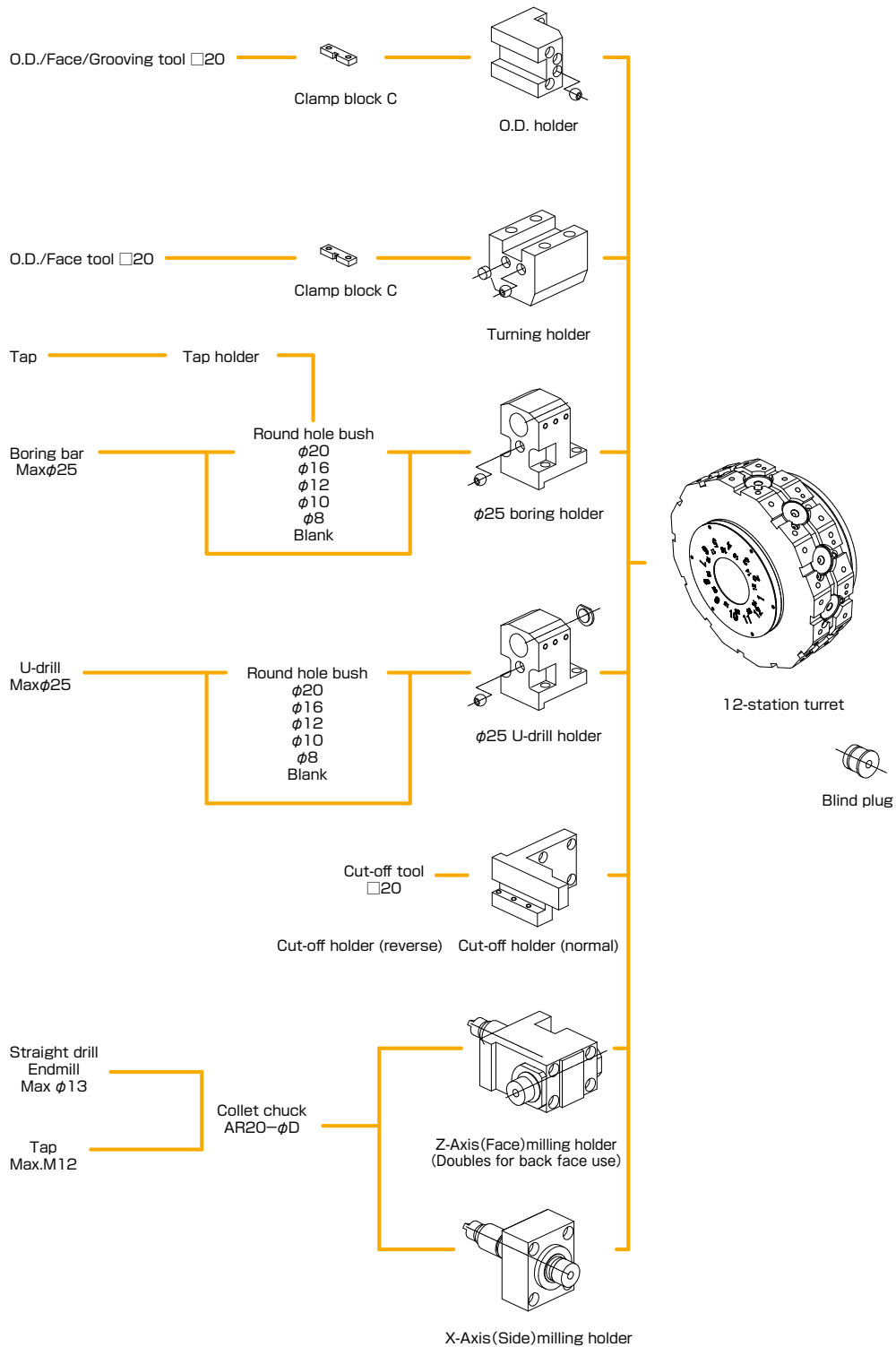

Turret interference

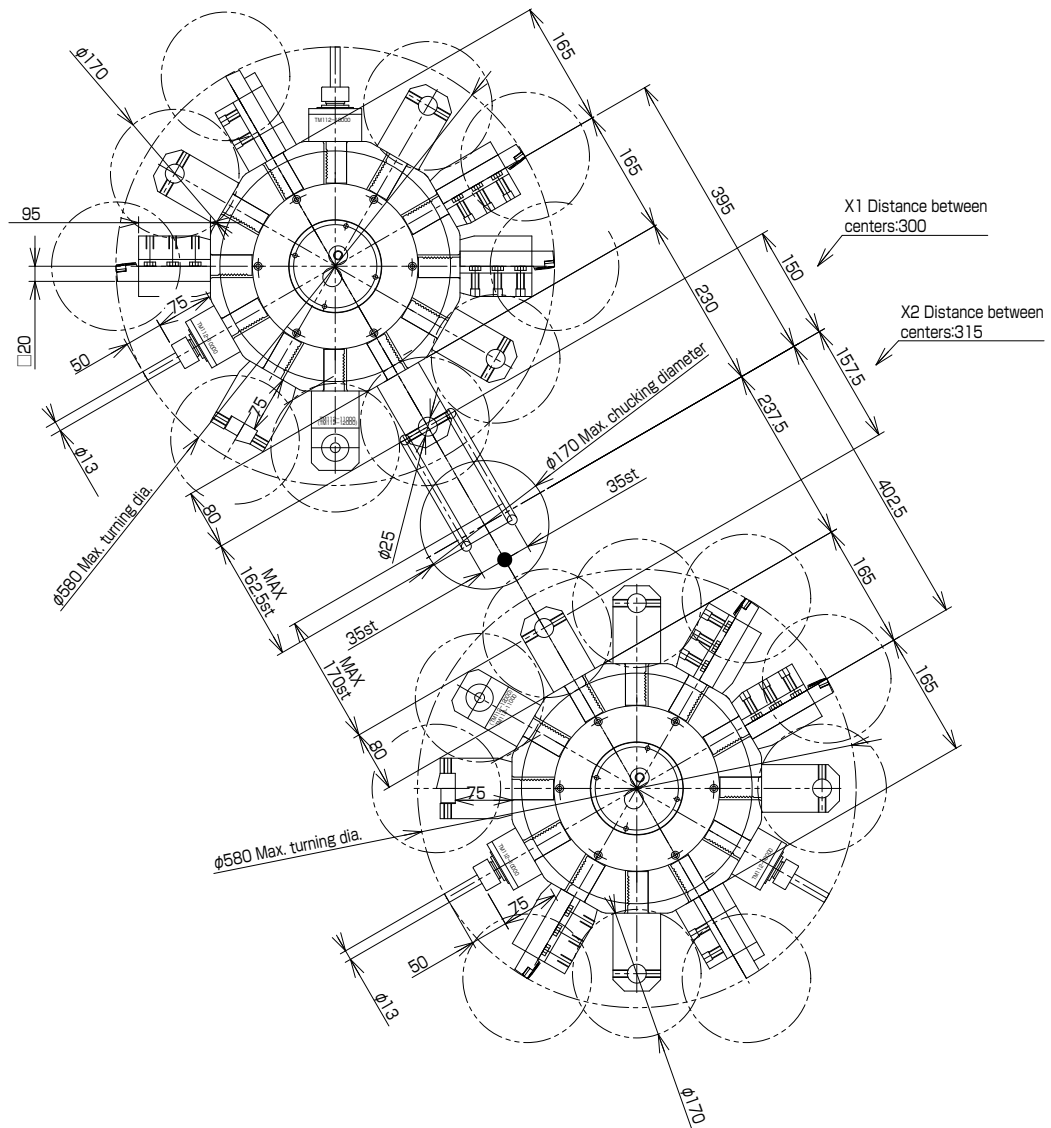

Stroke-Related Drawing

O.D. holder

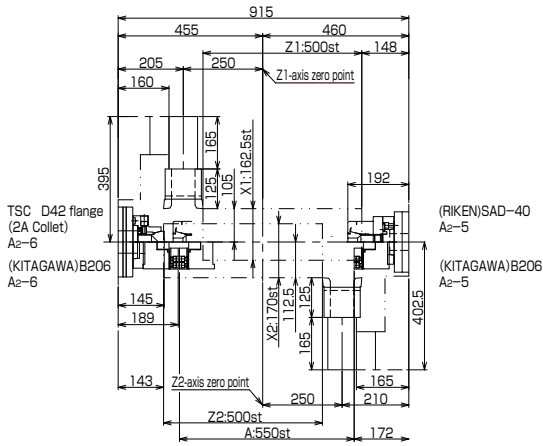

Z-Axis (Face) milling holder

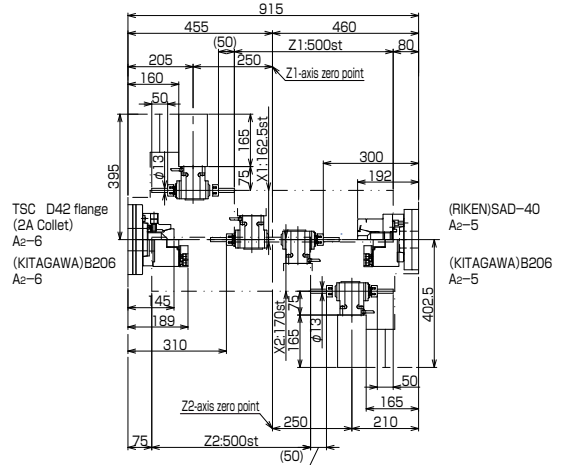

Boring holder, U-drill holder

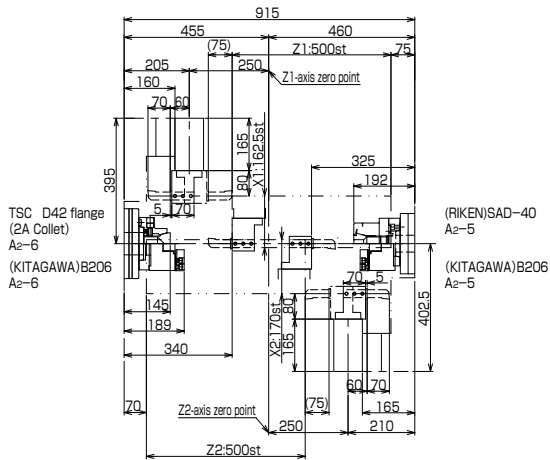

X-Axis (Side) milling holder

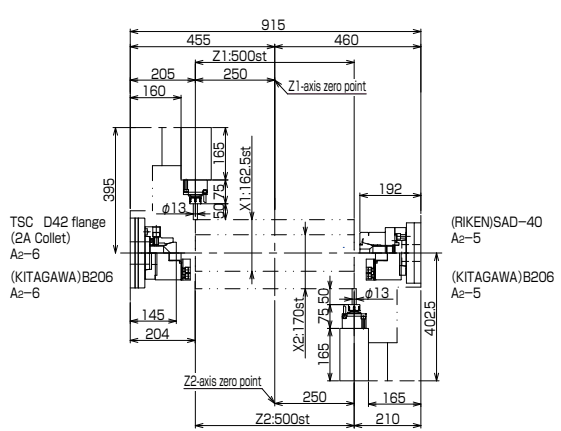

Turning holder

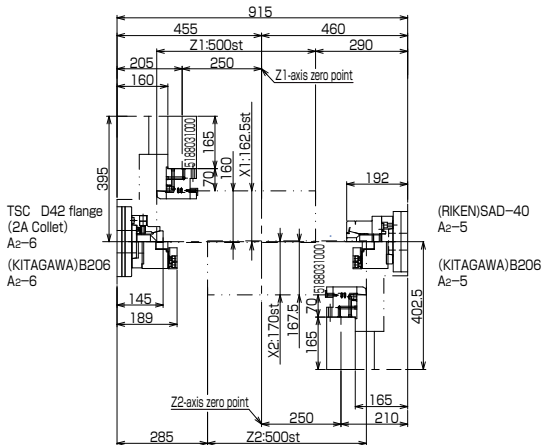

Cut-off holder

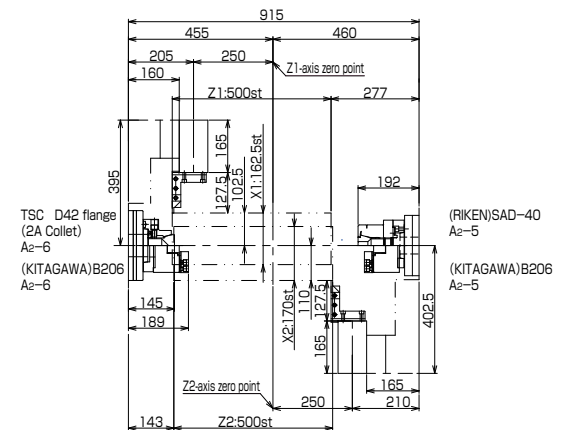

Unit(mm)

Tooling System [VDI]

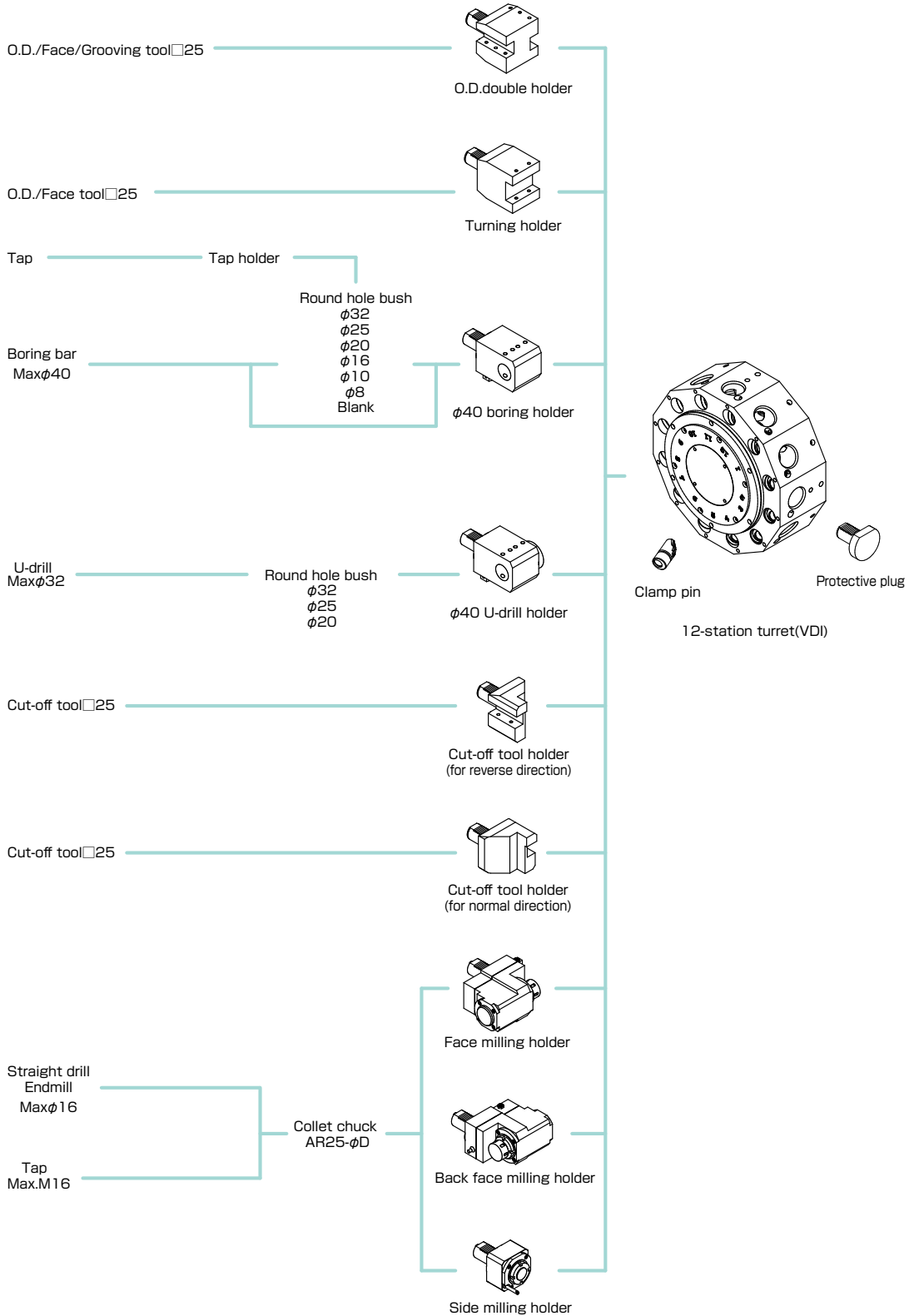

Unit(mm)

Turret interference

VDI40 turret

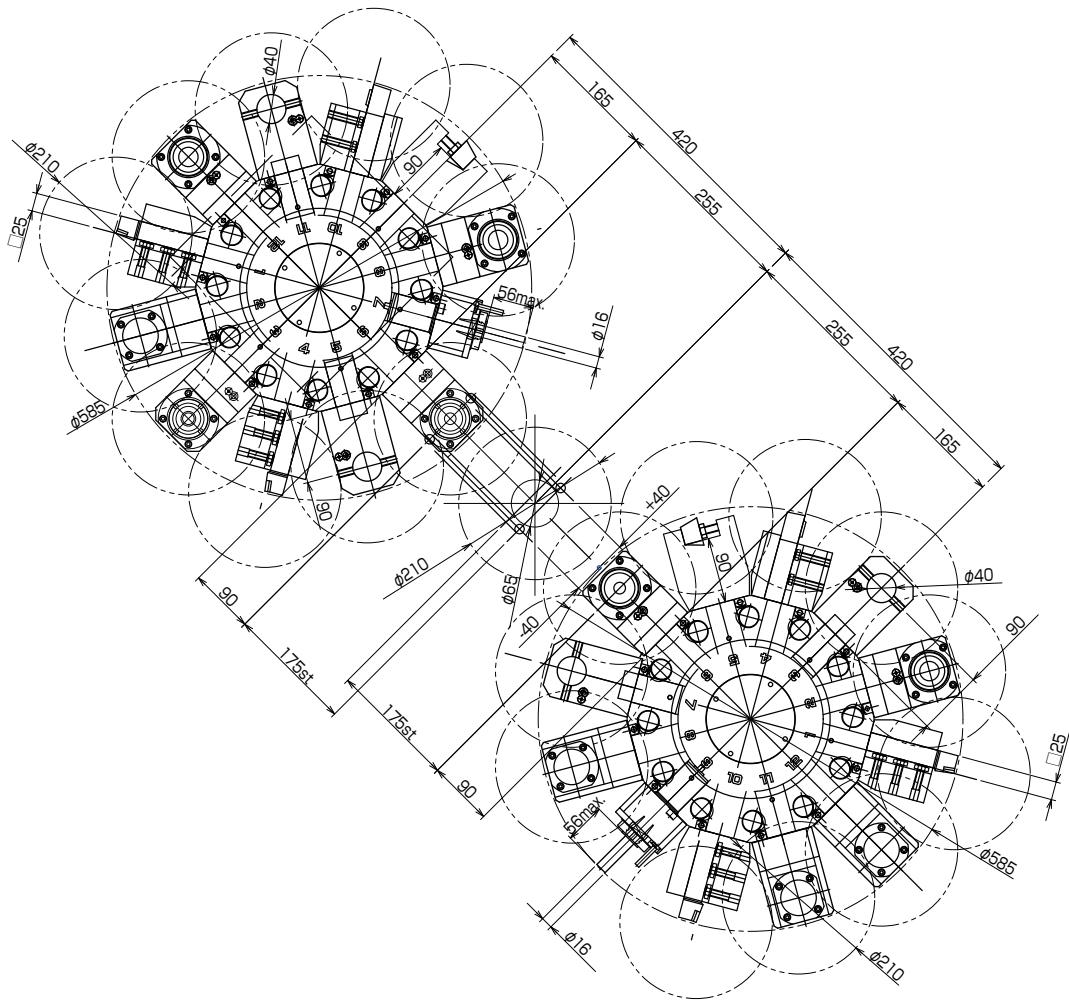

Unit(mm)

Stroke-Related Drawing

Turning holder

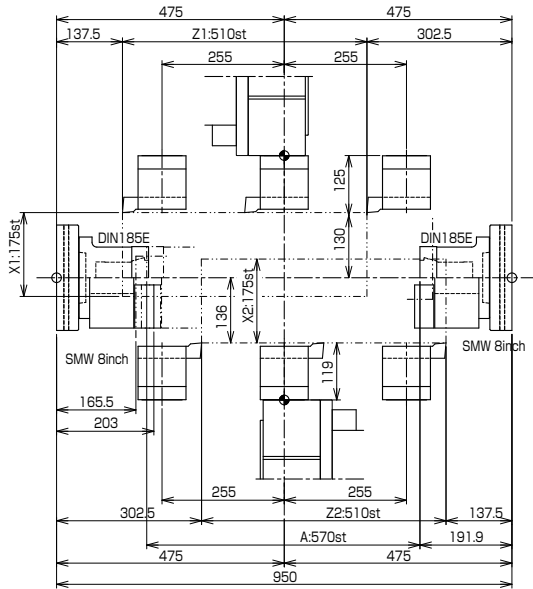

Boring holder

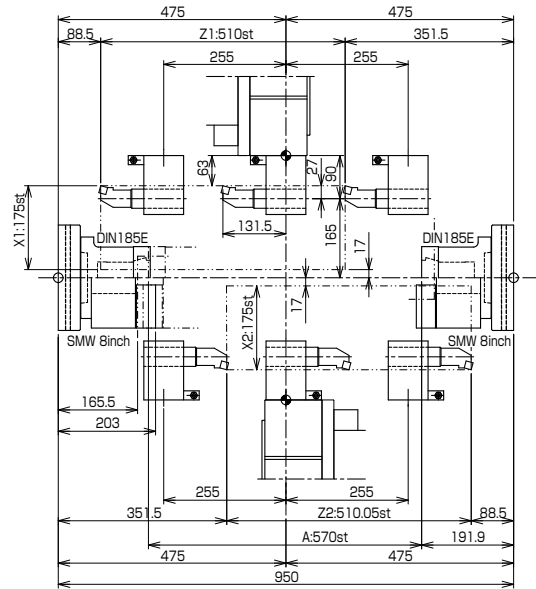

Z-Axis (Face) milling holder

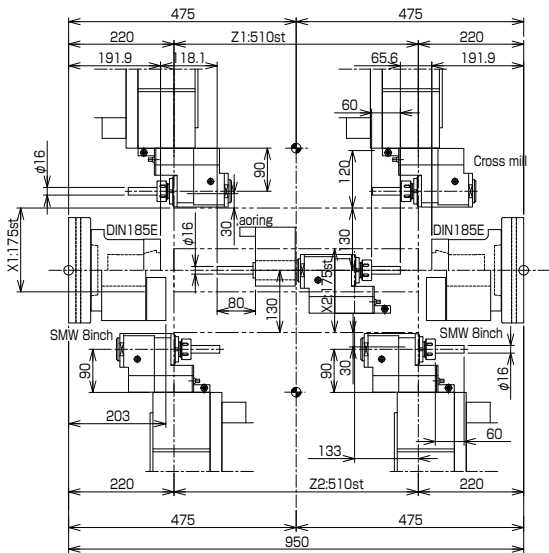

X-Axis (Side) milling holder

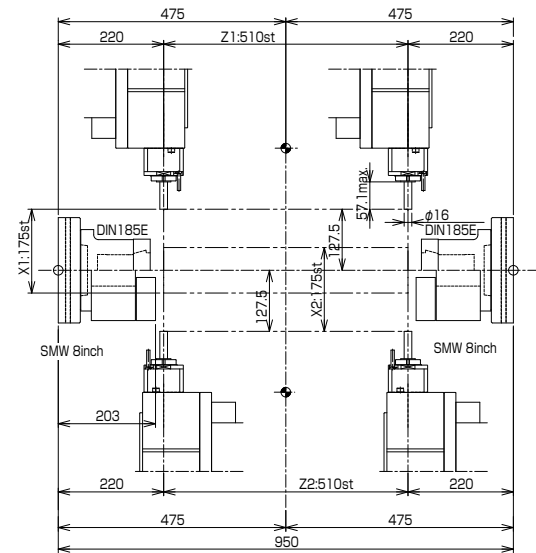

Unit(mm)

Machine Specifications

			XY-120 PLUS		XYT-51		XY-2000 PLUS	
Capacity	Item	Unit	Main-spindle		Sub-spindle			
		Max. turning diameter	mm	φ170		φ135		φ190
	Max. turning length	mm	330				150 (440 : One-side operation)	
	Max. bar diameter	mm	φ42	(φ51)	φ20		φ51	φ42
	Chuck size	Inch	Collet, 6		Collet, 5		Collet, 6	
Spindle	Spindle nose	JIS	A2-5	(A2-6)	A2-4		A2-6	A2-5
	Spindle bearing I.D.	mm	φ85	(φ100)	φ65		φ100	φ85
	Through-hole on spindle	mm	φ52	(φ61)	φ36		φ52	φ43
	Spindle speed	min ⁻¹	Max.5,000	(Max.4,000)	Max.5,000		Max.5,000	φ51 (φ65)
Tool post	Type		12-station turret		24st.		12-station turret	
	Tool shank	mm	□20		□20		□25 (VDI:40)	
	Boring holder I.D.	mm	φ25		φ25		φ40 (VDI:40)	
	Max. stroke	mm	X1:150 Z1:330 Y:±35 X2:150 Z2:440		X1:162.5 Z1:500 Y:±35 X2:170 Z2:500 A:550		X1:175 Z1:510 Y:±40 A:570 X2:175 Z2:510	
Power tools	Rapid traverse rate	m/min	X1:18 Z1:24 Y:12 X2:18 Z2:18		X1:18 Z1:30 Y:12 X2:18 Z2:30 A:30		X1:18 Z1:24 Y:12 A:30 X2:18 Z2:24	
	Tool storage capacity	pcs.	12		12 (One side)		12 (One side)	
	Rotation speed	min ⁻¹	Max.4,000		Max.4,000		Max.4,000	
	Capacity	mm	φ13		φ13		φ16	
Cs-axis	Drill	mm	φ13		φ13		φ16	
	Endmill	mm	φ13		φ13		φ16	
	Tap	mm	M8		M12		M16	
	Rapid traverse rate	deg/min	21,600		24,000		24,000	
Motors	C axis motor	kW	Cs-axis		AC 0.75		AC 0.75	
	Spindle motor	kW	AC7.5/5.5	(AC11/7.5)	AC5.5/3.7		AC18.5/15	AC11/7.5
	Feed motor	kW	X1:AC1.2 Z1:AC1.8 Y:AC0.75 X2:AC0.75 Z2:AC1.2		X1:AC1.8 Z1:AC1.8 Y:AC1.4 X2:AC1.8 Z2:AC1.8 A:AC1.2		X1:AC2.5 Z1:AC2.7 Y:AC2.5 A:AC2.7 X2:AC2.7 Z2:AC2.7	
	Coolant motor	kW	AC 0.25/0.25		AC 0.339		AC 0.339	
Size	Hydraulic motor	kW	AC1.5		AC 0.75		AC 0.75/0.75	
	Power tools motor	kW	AC3.7/2.2/1.5		AC3.7/2.2		AC3.7/2.2	
	Spindle center height	mm	1,050		1,240		1,220	
	LxWxH	mm	2,630 × 1,950 × 1,730		2,995×2,250×2,100		3,060×2,145×2,220	
	Machine weight	kg	4,500		7,400		8,100	
	Total electric capacity	KVA	27(31)		44		73	

() : Option

Standard Accessories

	XY-120 PLUS	XYT-51	XY-2000 PLUS
<input type="checkbox"/> Boring holder		2 sets	4 sets
<input type="checkbox"/> O.D. holder		2 sets	4 sets
<input type="checkbox"/> Cut-off holder		1 set	
<input type="checkbox"/> Collet flange		1 set ea. (Main, Sub)	
<input type="checkbox"/> Hydraulic chuck		Option	1 set ea. (#1, #2)
<input type="checkbox"/> Hydraulic chucking cylinder		1 set ea. (Main, Sub)	
<input type="checkbox"/> Y-axis function	1 set (Main)		1 set (#1 Turret)
<input type="checkbox"/> Spindle indexing device	Cs-axis 1 set ea. (Main, Sub)	Cs-axis 1 set ea. (Main, Sub)	C-axis 1 set ea. (#1, #2)
<input type="checkbox"/> Power tools drive unit	1 set (Main)		1 set (For both turrets)
<input type="checkbox"/> Sub-spindle		1 set	
<input type="checkbox"/> Coolant unit	1 set (200lit.)	1 set (360lit.)	1 set (405lit.)
<input type="checkbox"/> Service tool kit		1 set	
<input type="checkbox"/> TAKAMAZ Instruction manual		1 set	

Optional Accessories

	XY-120 PLUS	XYT-51	XY-2000 PLUS
<input type="checkbox"/> Tool holders		○	
<input type="checkbox"/> Stroke adjusting cylinder		○	
<input type="checkbox"/> Collet chucks		○	
<input type="checkbox"/> Hydraulic chucks	○(Main:6 Inch Sub:5 Inch)		○
<input type="checkbox"/> Chuck clamp detector	○	(Standard)	○
<input type="checkbox"/> Sub-spindle parts ejector	○	(Standard)	○
<input type="checkbox"/> VDI 12-station turret			○
<input type="checkbox"/> Sub turret (□16, φ20)	○(12-station)		
<input type="checkbox"/> TAKAMAZ loader system	○		
<input type="checkbox"/> Bar feeder system		○	
<input type="checkbox"/> Unloader unit (Out-conveyor)	○	(Standard)	○
<input type="checkbox"/> Work set detector		○	
<input type="checkbox"/> Cut-off check device		○	
<input type="checkbox"/> Power tools (Face / Side milling)	○		○
<input type="checkbox"/> Chip conveyor (Floor type/Spiral type)		○(Right)	
<input type="checkbox"/> Air blow unit (Front)		○	
<input type="checkbox"/> Air blow unit (Rear)	○		○
<input type="checkbox"/> Rear coolant unit		○	
<input type="checkbox"/> Signal light (1-tier / 2-tier / 3-tier)		○	
<input type="checkbox"/> Automatic fire extinguisher		○	
<input type="checkbox"/> Automatic power shut-off device		○	
<input type="checkbox"/> Automatic door system	○		○
<input type="checkbox"/> Special color		○	
<input type="checkbox"/> Others※		○	

Controller Specifications

	XY-120 PLUS	XYT-51	XY-2000 PLUS
Item	TAKAMAZ&FANUC Oi-TD	TAKAMAZ & FANUC 32i-B	TAKAMAZ & FANUC 31i-A
Controlled axes	7 axes (X1, Z1, C1, Y, X2, Z2, C2)	8 axes (X1, Z1, C1, Y, X2, Z2, C2, A)	
Simultaneously controllable axes		Simultaneous 4 axes	
Least input increment		0.001mm (X in diameter)	
Least command increment	X: 0.0005mm Z, Y: 0.001mm	X: 0.0005mm Z, Y, A: 0.001mm C: 0.001deg.	
Auxiliary function		M3 digits	
Spindle function		S4 digits	
Tool function		T4 digits	
Tape code		EIA(RS232C) / ISO(840)automatic recognition	
Cutting feedrate	1 ~ 5,000mm/min	1 ~ 7,000mm/min	1 ~ 5,000mm/min
Command system		Incremental / Absolute	
Linear interpolation		G01	
Circular interpolation		G02, G03	
Cutting feedrate override		0 ~ 150%	
Rapid traverse override	F0, 100%	F0, 25%, 50%, 100%	F0, 50, 100%
Program number	4 digits	Program file name 32 characters	
Backlash compensation		0 ~ 9,999 μ m	
Program memory capacity	1Mbyte (2,560m) (Dual systems total)	64Kbyte(160m) (Dual systems total)	
Tool offsets	128 sets(Dual systems total)	99 sets (Dual systems total)	32 sets (Dual systems total)
Registered programs	800 pcs.(Dual systems total)	63 pcs. (Dual systems total)	
Tool geometry / Wear offset		Standard	
Canned cycle		G90, G92, G94	
Radius designation on arc		Standard	
Tool offset measurement input		Standard	
Background editing		Standard	
Direct drawing dimension programming	Standard		Option
Custom macro		Standard	
Additional custom macro common variables	#100 ~ #199, #500 ~ #999		Option
Pattern data input	Standard		—
Nose R compensation		G40, G41, G42	
Inch / Metric conversion	G20 / G21		Option
Programmable data input		G10	
Run hour / Parts count display	Standard		Option
Extended part program editing		Standard	
Multiple repetitive cycle		G70 ~ G76	
Multiple repetitive cycleII	Pocket-shaped		Option
Spindle synchronous control		Standard	
Sub-spindle torque skip		Standard	
Y-axis offset		Standard	
Canned drilling cycle		Standard	
Constant surface speed control		G96, G97	
Continuous thread cutting		G32	
Variable lead thread cutting	G34		Option
Thread cutting retract	Standard	Option	—
Clock function		Standard	
Help function		Standard	
Alarm history display	50 pcs.		60 pcs.
Self-diagnosis function		Standard	
Self-diagnosis function		Up to 10 loops	
Decimal point input		Standard	
2nd reference point return		G30	
Work coordinate system setting		G50, G54 ~ G59	
Rigid tapping		For Power Tool only	
Polar coordinate interpolation		Standard	
Cylindrical interpolation		Standard	
Stored stroke check 1		Standard	
Stored stroke check 2,3		Standard	
Input / Output interface	USB Flash Memory, Memory card, Ethernet		RS232C, Memory card, Ethernet
Alarm message		Standard	
Graphic display		Standard	
Spindle orientation		Standard	
Conversational programming with graphic function	Standard		—
Abnormal load detection		Standard	—
Overlap Cutting Process		Standard	—
Balance cut	—		G68, 69
Manual handle trace		Standard	—
Automatic data backup		Max.3	—
Automatic screen deletion function		Standard	
TAKAMAZ management support function		Work / Tool counter, Tool load monitor, Others	
TAKAMAZ maintenance function		Standard	
FANUC set of manuals	CD-ROM	DVD-ROM	Bound

Optional Specifications

	XY-120 PLUS	XYT-51	XY-2000 PLUS
Item	TAKAMAZ&FANUC Oi-TD	TAKAMAZ & FANUC 32i-B	TAKAMAZ & FANUC 31i-A
Tool life management			
Multiple M codes in one block		Max. 3	
Dynamic graphic display*			—
Manual guide i*			
Helical interpolation			
RS232C			(Standard)
FANUC instruction manuals	Bound		(Standard)

※These cannot be used together.

XY-120 PLUS

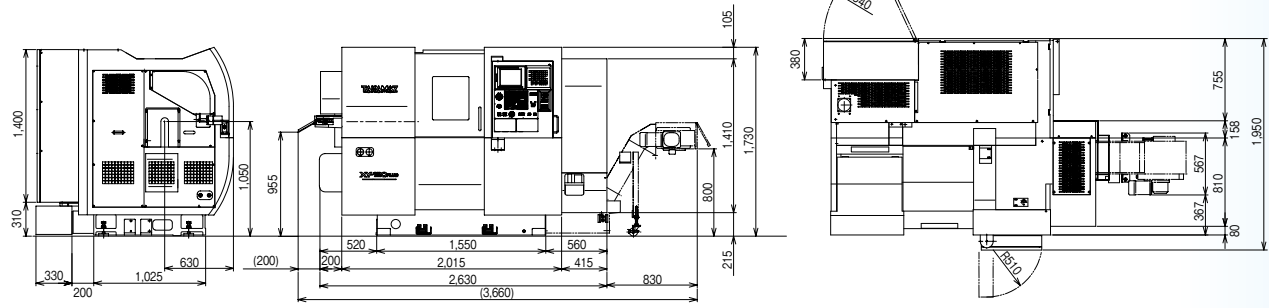

Unit(mm)

XYT-51

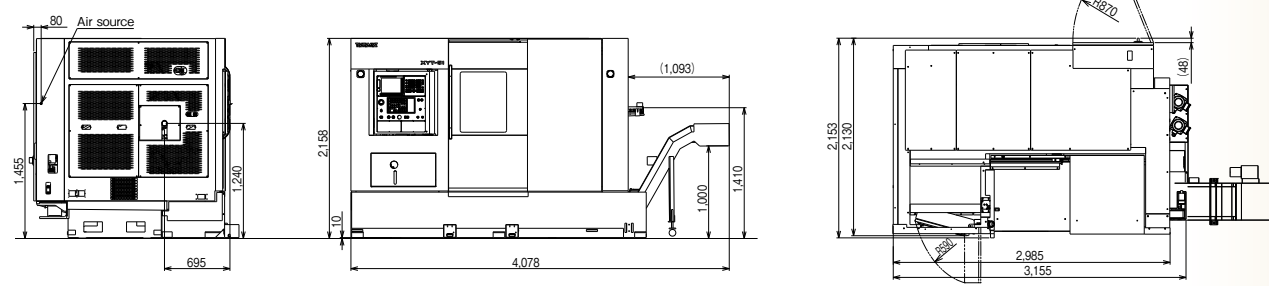

Unit(mm)

XY-2000 PLUS

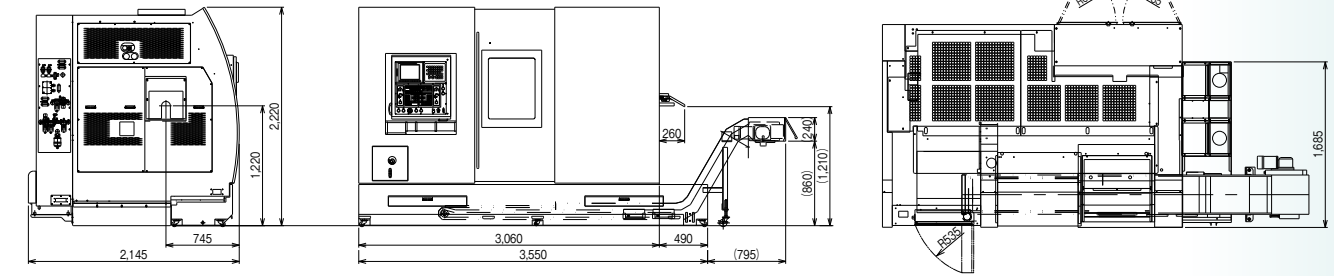

Unit(mm)

TAKAMAZ

www.takamaz.co.jp

TAKAMATSU MACHINERY CO.,LTD.

■HEAD OFFICE & PLANT
1-8 ASAHIGAOKA HAKUSAN-CITY ISHIKAWA JAPAN. 924-8558 TEL +81-(0)76-274-1403 FAX +81-(0)76-274-8530

TAKAMATSU MACHINERY USA INC.

■CHICAGO HEAD OFFICE
1280 LANDWEIER ROAD ELK GROVE VILLAGE, IL 60007 USA TEL +1-(0)847-981-8577 FAX +1-(0)847-981-8599
■CINCINNATI OFFICE
5233 MULHAUSER ROAD, WEST CHESTER TOWNSHIP, OH 45011 USA TEL +1-(0)513-870-9777 FAX +1-(0)513-870-0325
■GREENVILLE OFFICE
506 MATRIX PARKWAY PIEDMONT, SC 29673 USA TEL +1-(0)847-981-8577

TAKAMAZ MACHINERY EUROPE GmbH

INDUSTRIEGEBIET, DIEPENBROICH 27 D-51491 OVERATH, GERMANY
TEL +49-(0)2206-866-150 FAX +49-(0)2206-866-123

TAKAMAZ MACHINERY (HANGZHOU) CO.,LTD.

■HANGZHOU HEAD OFFICE
NO.6800, JIANGDONG 3RD ROAD, JIANGDONG INDUSTRIAL PARK, XIAOSHAN, HANGZHOU, ZHEJIANG, CHINA
TEL +86-(0)571-8287-9709 FAX +86-(0)571-8215-3732
■GUANGZHOU OFFICE
ROOM 1316, NO.2, KEHUI FOURTH STREET, NO.99 OF SCIENCE ROAD, LUOGANG DISTRICT, GUANGZHOU
TEL +86-(0)20-8210-9921 FAX +86-(0)20-8210-9921

TAKAMATSU MACHINERY (THAILAND) CO.,LTD.

■BANGKOK HEAD OFFICE
888/59 MOO 9, TAMBOL BANGPLA, AMPHUR BANGPLEE, SAMUTPRAKARN PROVINCE, THAILAND
TEL +66-(0)2-136-7831 FAX +66-(0)2-136-7834
■EASTERN SEABOARD BRANCH
848/14 MOO 3, TAMBOL BO WIN, AMPHUR SIRACHA, CHONBURI 20230
TEL +66-(0)38-182-509 FAX +66-(0)38-182-510

TP MACHINE PARTS CO.,LTD.

128/345 MOO 1 THEPARAK ROAD, BANGSAOTHONG SUBDISTRICT, BANGSAOTHONG DISTRICT, SAMUTPRAKARN
TEL +66-(0)2-706-3820 FAX +66-(0)2-706-3822

PT.TAKAMAZ INDONESIA

JL. FESTIVAL BOULEVARD BLOK AA 11 NO.30.31 GRAND WISATA TAMBUN, BEKASI 17510
TEL +62-(0)21-8261-6431 FAX +62-(0)21-8261-6430

TAKAMAZ MACHINERY MEXICO,S.A.DE C.V.

AVENIDA DE LOS INDUSTRIALES 522, LOCAL 4, INDUSTRIAL JULIAN DE OBREGON, 37290 LEON, GUANAJUATO MEXICO
TEL +52-477-784-0468

TAKAMATSU MACHINERY VIETNAM CO.,LTD

NO.25, NGUYEN LUONG BANG, TAN PHU WARD, DISTRICT 7, HO CHI MINH CITY, VIETNAM
TEL +84-(0)28-5417-3917 FAX +84-(0)28-5417-3919

Precautions Related to Foreign Exchange and Foreign Trade Control Laws

This product (machine and ancillary equipment) may fall under the category of controlled goods by the foreign exchange and foreign trade control laws. As such, the exportation must be authorized by the Japanese government as stipulated in the laws. This product is manufactured in accordance with the regulations and standards that prevail in the country or region of destination.

The user must not export, sell, or relocate the product, to any country with different regulations or standards.



This brochure is made from 60% recycled paper.